

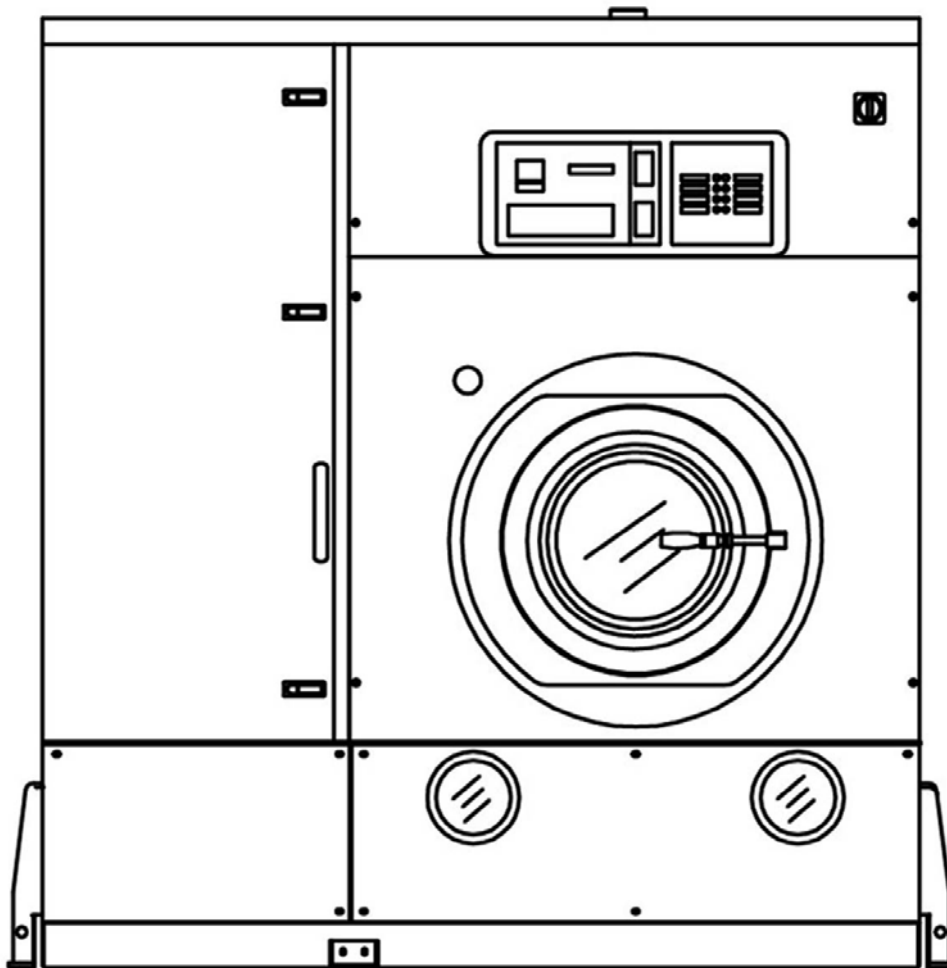

TECHNICAL INFORMATION



HXL 8025 C



MACHINE CAPACITY	25 Kg	55÷60 Lbs
-------------------------	--------------	------------------

BASKET		
Diameter	1000 mm	<i>39.4 inches</i>
Depth	640 mm	<i>25.2 inches</i>
Volume	500 Lt	<i>17.7 cu.ft</i>
Wash speed	20 ÷ 50 rpm	
Extract speed	300 ÷ 520 rpm	
Door opening	500 mm	<i>20 inches</i>

SOLVENT TANKS		
Useful volume tank 1	145 Lt	<i>38 gal</i>
Useful volume tank 2	145 Lt	<i>38 gal</i>
Useful volume tank 3	-	-
FLOOR SAFETY TANK CAPACITY	327 Lt	<i>86 gal</i>

ELECTRIC POWER	400V - 3~50Hz		220V - 3~60Hz	
Wash - Extract (with Inverter)	*2.7-7.5 Hp	*2-5.5 Kw	<i>*2.7-7.5 Hp</i>	<i>*2-5.5 Kw</i>
Solvent pump motor	1 Hp	0.75 Kw	<i>1 Hp</i>	<i>0.75 Kw</i>
Fan motor	2 Hp	1.5 Kw	<i>3.5 Hp</i>	<i>2.65 Kw</i>
Refrigerator compressor	5.7 Hp	4.26 Kw	<i>7 Hp</i>	<i>5.26 Kw</i>
Remote Condenser (Optional)	0.21 Hp	0.16 Kw	<i>0.21 Hp</i>	<i>0.16 Kw</i>
Heater electric elements	-	9 Kw	-	<i>9 Kw</i>
Air motor compressor (Optional)	0.5 Hp	0.38 Kw	<i>0.5 Hp</i>	<i>0.38 Kw</i>

*** POWER CHANGES ACCORDINGLY TO THE USE OF THE MACHINE**

NOTE: Acoustic emission level of the machine is lower than 70 dB (A)



FILTRATION AVAILABLE IN THIS MODEL

FOUR LARGE CARTRIDGE - KR (2 Filters Units)			
	Vol. large cartridge housing KR	105x4=420 Lt	<i>27.8x4=111.2 gal</i>
	Area large cartridge KR	2.6x16=41.6 mt²	<i>28x16=448 ft²</i>
	Cartridges quantity KR	nr 4x4=16	



DIMENSIONS AND WEIGHTS

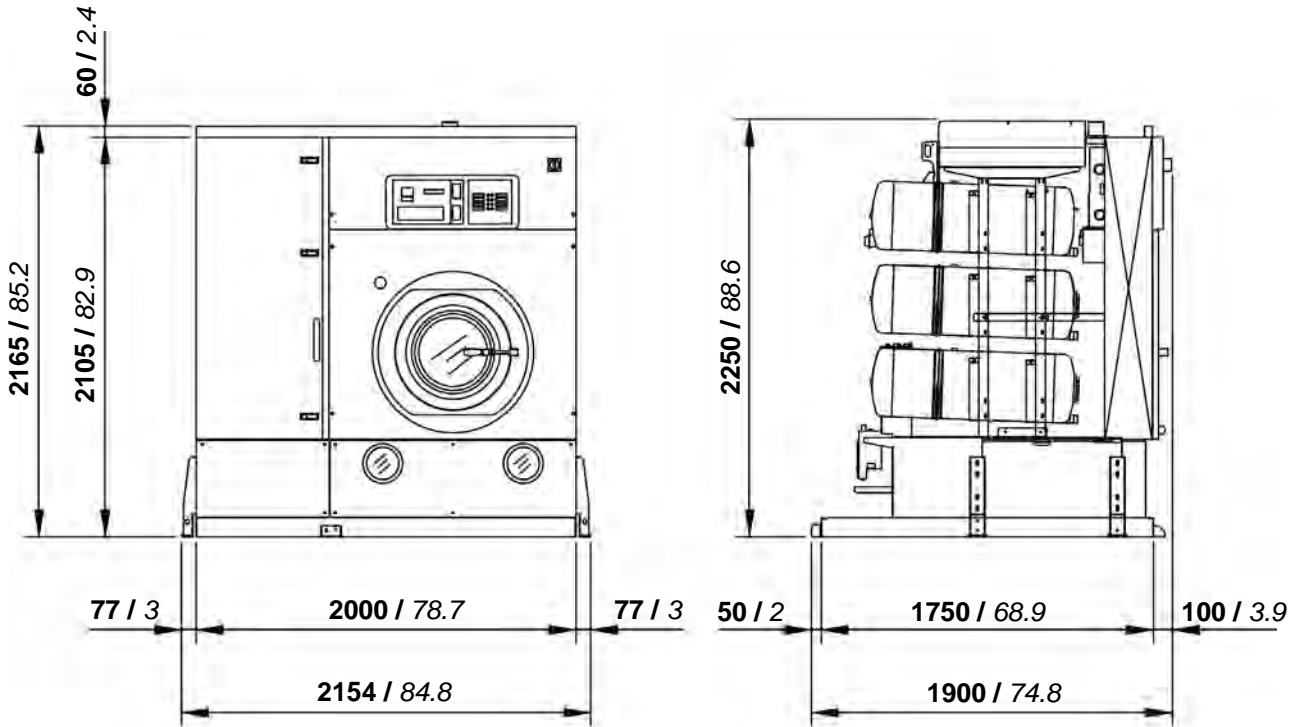

mm / inches

CHARGES		
Empty machine weight	1750 Kg	3858 Lbs
Machine weight with solvent	2297 Kg	5064 Lbs
Static charge on the floor with solvent	656 Kg/m²	134 Lbs/ft²
Dynamic charge on the floor (+10%)	1086 Kg/m²	222 Lbs/ft²



PACKAGED MACHINE DIMENSIONS AND WEIGHTS

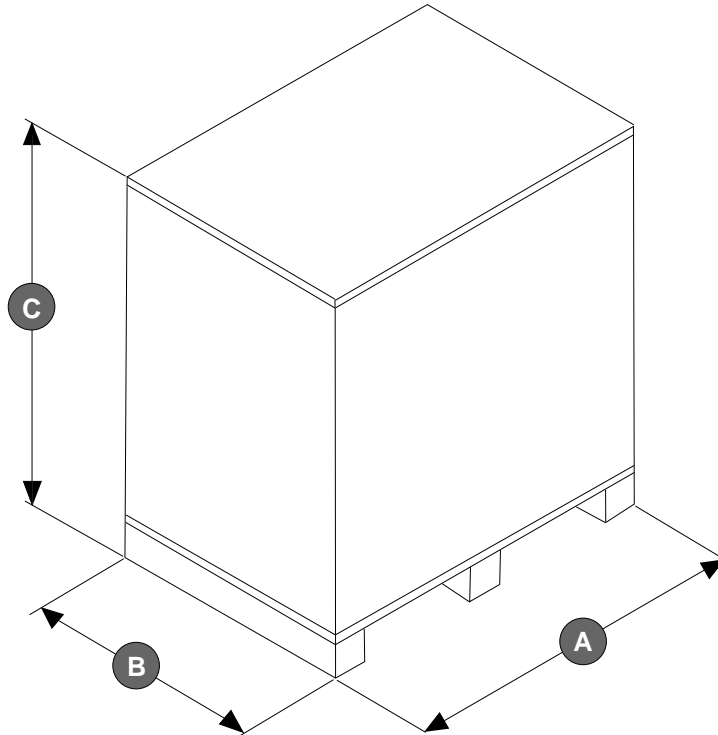

PACKAGED MACHINE DIMENSIONS							
Machine type		Carton		Wooden cage		Wooden case	
Standard	A	- mm	- inches	- mm	- inches	- mm	- inches
	B	- mm	- inches	- mm	- inches	- mm	- inches
	C	- mm	- inches	- mm	- inches	- mm	- inches

PACKAGED MACHINE WEIGHTS						
Machine type	Carton		Wooden cage		Wooden case	
Standard	- Kg	- Lbs	- Kg	- Lbs	- Kg	- Lbs



FIXING POINTS

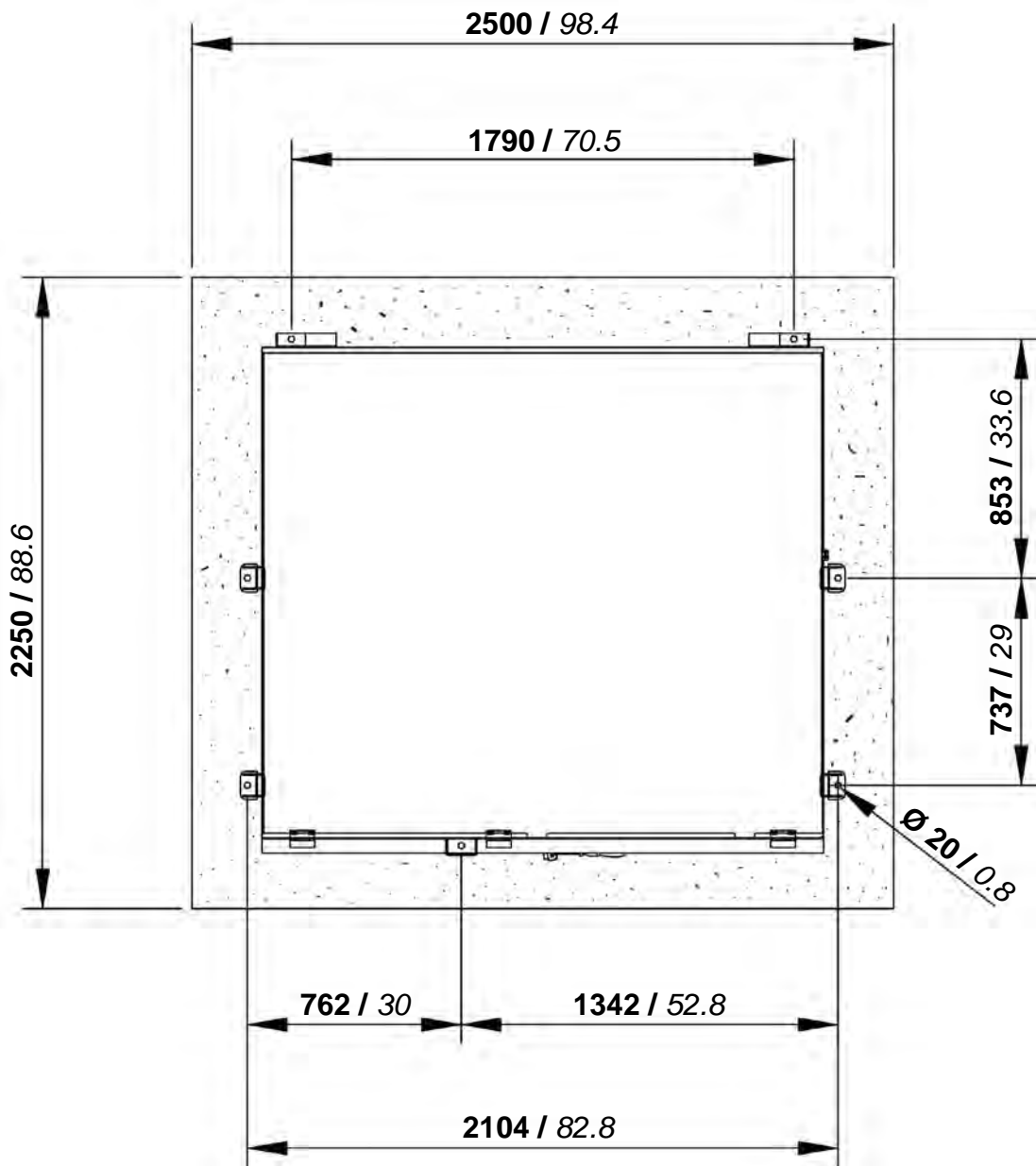
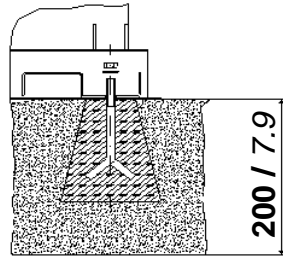

mm / inches





CONNECTIONS

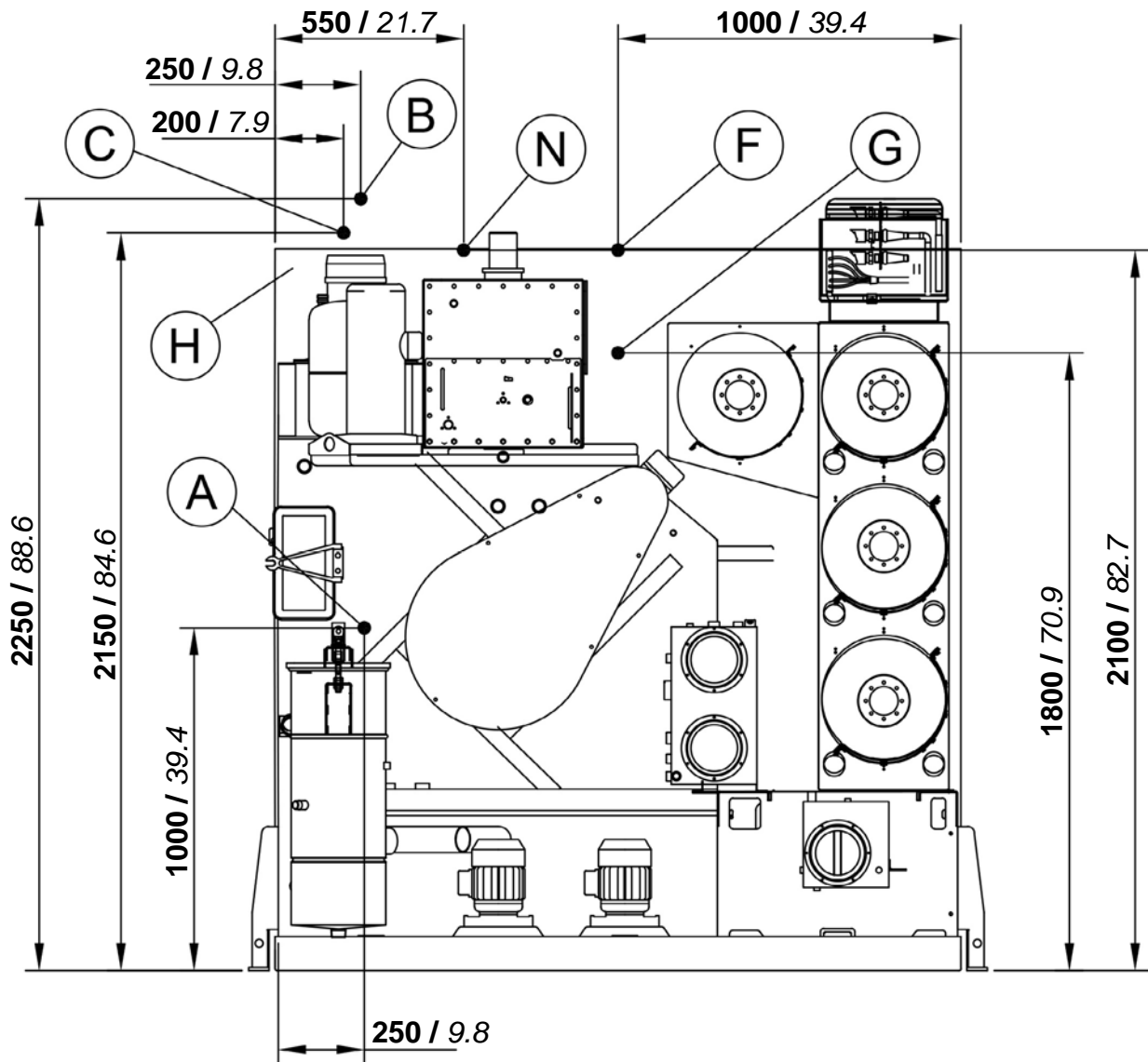

mm / inches

A	Compressed air inlet	Ø 6mm	Ø 1/4"
B	Water inlet (Optional)	Ø 3/4"	
C	Water outlet (Optional)	Ø 3/4"	
D	-	-	
E	-	-	
F	Steam heater inlet (Optional)	Ø 1/2"	
G	Condensate heater outlet (Optional)	Ø 1/2"	
H	Electric connection		
N	Nitrogen feeding connection (N ₂)		



NECESSARY QUANTITY OF SOLVENT TO FILL THE MACHINE				
Machine version - without Filters	290 Lt	223 Kg	<i>76 gal</i>	<i>492 Lbs</i>
Machine version - 4 KR Filters (2 Filters Units)	710 Lt	547 Kg	<i>187 gal</i>	<i>1203 Lbs</i>

INFORMATION FOR THE ELECTRICAL CONNECTIONS (400V - 3~50Hz)		
ELECTRIC Version	- Kw	- Amp
STEAM Version	8.5 Kw	31 Amp
Dissipated heat	- Kcal	

INFORMATION FOR THE ELECTRICAL CONNECTIONS (220V - 3~60Hz)		
ELECTRIC Version	- Kw	- Amp
STEAM Version	9.5 Kw	45 Amp
Dissipated heat	- Kcal	

GENERAL INFORMATION		
Required water capacity	10 Lt/min	<i>2.6 gal/min</i>
Required water pressure	2 ÷ 3 bar	<i>29 ÷ 44 psi</i>
Required water temperature	18 ÷ 23 °C	<i>65 ÷ 73 °F</i>
Required air pressure	7 ÷ 8 bar	<i>100 ÷ 115 psi</i>
Required steam pressure (Steam Version)	3.5 ÷ 4 bar	<i>51 ÷ 58 psi</i>
Required steam availability (Steam Version)	15 ÷ 20 Kg/h	<i>33 ÷ 44 Lbs/h</i>

All technical data are subject to change without notice.