

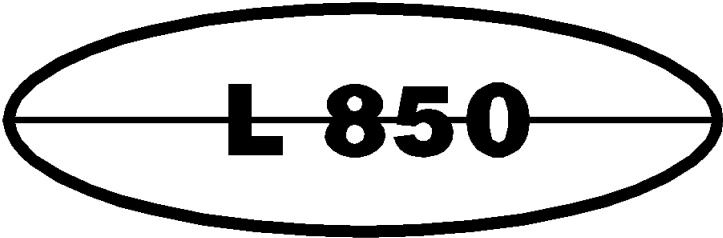

**TECHNICAL INFORMATION**

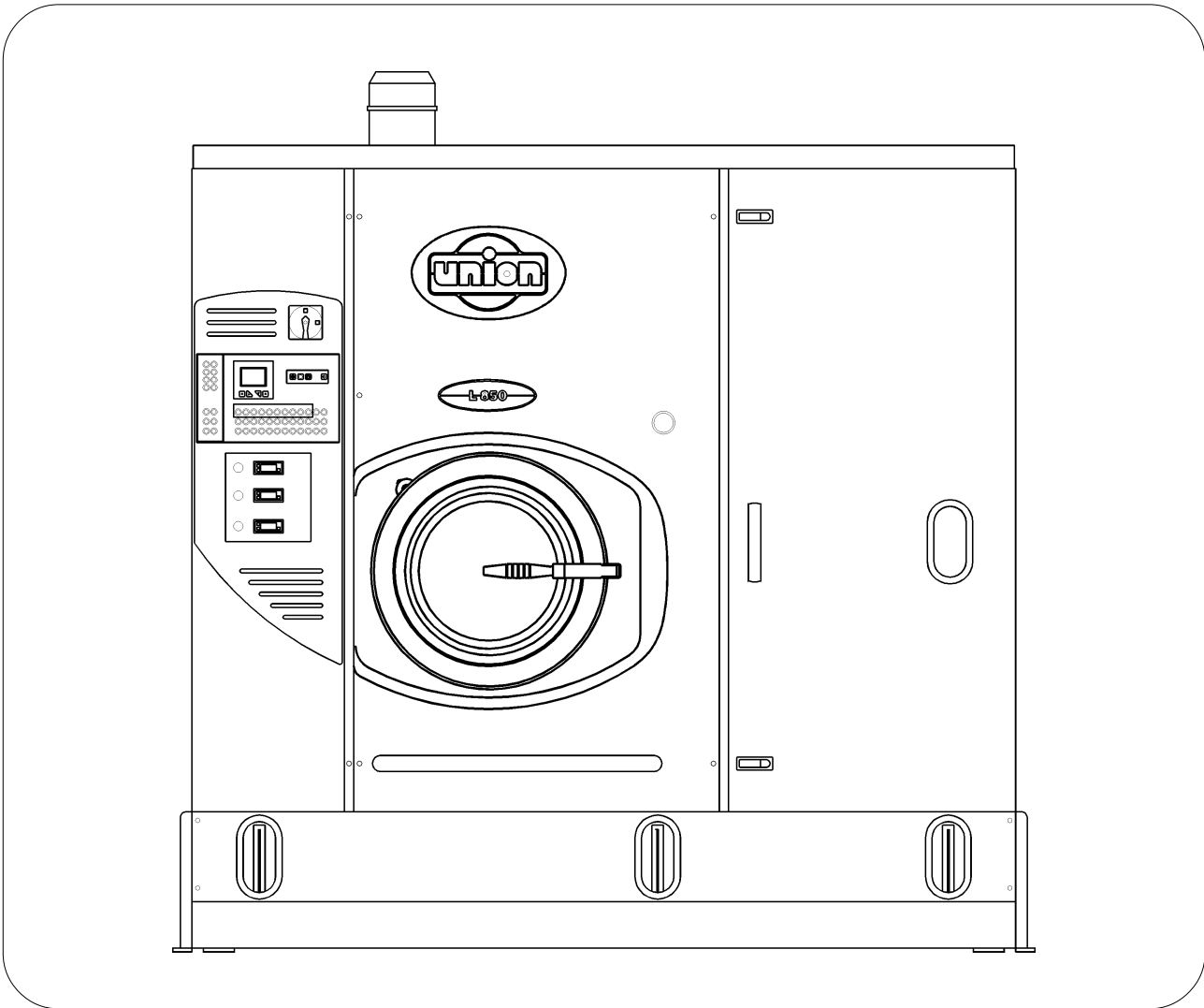



<b>WORKING MACHINE WITH SOLVENT</b>	<b>PERCHLORETHYLENE</b>	
<b>MACHINE CAPACITY</b> (RATIO 1:20)	Lbs	45 ÷ 50

**BASKET**

Diameter	inches	39.4
Depth	inches	20
Volume	cu-ft	14.1
Wash speed	rpm	33
Extract speed	rpm	190 ÷ 380
Door opening	inches	20

**SOLVENT TANKS**

Useful volume tank 1	gal	42
Useful volume tank 2	gal	42
Useful volume tank 3	gal	53
<b>FLOOR SAFETY TANK CAPACITY</b>	gal	114

**DESTILLATOR**

Useful volume at half inspection	gal	68
Total volume	gal	86
Boiler water capacity	gal	2.6

**ELECTRIC POWER (220 V - 60 Hz)**

Wash motor	Hp	1.5	Kw	1.13
Extract motor	Hp	4.5	Kw	3.38
Solvent pump motor	Hp	1	Kw	0.75
Fan motor	Hp	3	Kw	2.25
Refrigerator compressor MT81	Hp	6.5	Kw	4.88
Nylon filter motor	Hp	0.75	Kw	0.55
Still residue pump	Hp	0.75	Kw	0.55
Exhaust fan motor	Hp	0.18	Kw	0.13
Still electric elements	Hp		Kw	13.5
Heater electric elements with Turbo Still	Hp		Kw	1 x 6 = 6
Heater electric elements without Turbo Still	Hp		Kw	1 x 9 = 9
Air motor compressor	Hp	0.5	Kw	0.37
Fan motor Recuper - 303	Hp	1	Kw	0.75

**NOTE: Acoustic emission level of the machine is lower than 70 dB (A)**

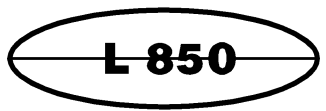

**FILTRATION AVAILABLE IN THIS MODEL**

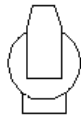
<b>Version 03 - ONE NYLON FILTER</b>			
	Volume nylon filter housing	gal	20
	Nylon filter area	ft <sup>2</sup>	59
	Filter disks	nr	39

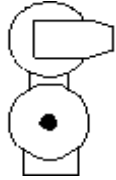
<b>Version - 04 ONE NYLON FILTER AND ONE DECOLORATING FILTER KR</b>			
	Volume nylon filter housing	gal	20
	Nylon filter area	ft <sup>2</sup>	59
	Filter disks	nr	39
	KR Decolorating housing volume	gal	22,5
	KR Decolorating filter area	ft <sup>2</sup>	28 x 3 = 56
	KR cartridges quantity	nr	3

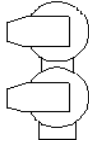
<b>Version 05 - TWO NYLON FILTER</b>			
	Volume nylon filter	gal	20 x 2 = 40
	Nylon filter area	ft <sup>2</sup>	59 x 2 = 118
	Filter disks	nr	39 x 2 = 78

<b>Version 08 - ONE NYLON FILTER AND ONE DECO FILTER - PR</b>			
	Volume nylon filter	gal	20
	Nylon filter area	ft <sup>2</sup>	59
	Filter disks	nr	39
	PR - Deco filter volume	gal	6,6
	PR - Cartridge quantity	ft <sup>2</sup>	21,5
	Decolorating carbon quantity	Lbs	8,8

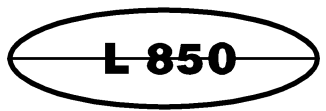

<b>Version - 10 ONE NYLON ONE CARTRIDGE -KR ONE DECOLORATING PR</b>			
	Volume nylon filter housing	gal	20
	Nylon filter area	ft <sup>2</sup>	59
	Filter disks	nr	39
	KR Decolorating housing volume	gal	22,5
	KR Decolorating filter area	ft <sup>2</sup>	28 x 3 = 84
	KR Decolorating cartridges	nr	3
	PR - Deco filter volume	gal	6,6
	Tubes	nr	1
	PR - Cartridge quantity	nr	2
	Decolorating carbon quantity	Lbs	8,8

<b>Version 11 - TWO NYLON FILTER AND ONE DECO FILTER - PR</b>			
	Volume nylon filter	gal	20 x 2 = 40
	Nylon filter area	ft <sup>2</sup>	59 x 2 = 118
	Filter disks	nr	39 x 2 = 78
	PR - Deco filter volume	gal	6,6
	Tubes	nr	1
	PR - Cartridge quantity	nr	2
	Decolorating carbon quantity	Lbs	8,8

<b>Version 14 - TWO NYLON FILTER AND TWO DECO FILTER - PR</b>			
	Volume nylon filter	gal	20 x 2 = 40
	Nylon filter area	ft <sup>2</sup>	59 x 2 = 118
	Filter disks	nr	39 x 2 = 78
	PR - Deco filter volume	gal	6,6 x 2 = 13,2
	Tubes	nr	2
	PR - Cartridge quantity	nr	4
	Decolorating carbon quantity	Lbs	17,6

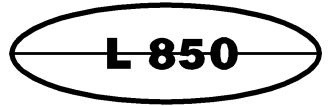

**DIMENSIONS AND WEIGHTS - STANDARD VERSION**

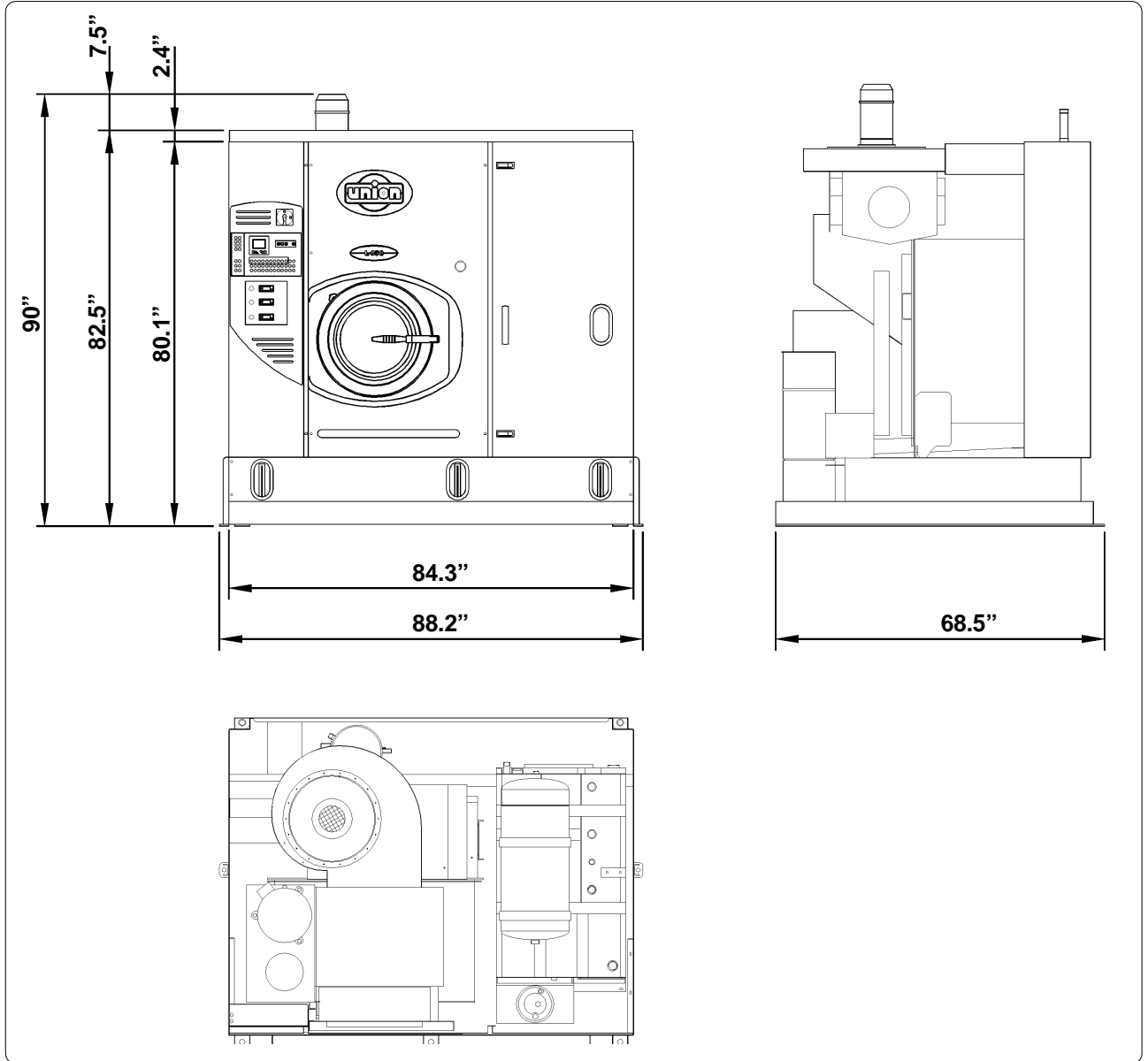

<b>CHARGES</b>		
Empty machine weight	Lbs	4320
Machine weight with solvent	Lbs	6857
Static charge on the floor with solvent	Lbs/ft <sup>2</sup>	171
Dynamic charge on the floor (+10%)	Lbs/ft <sup>2</sup>	212

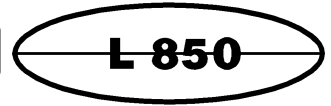

**DIMENSIONS AND WEIGHTS - U2000 VERSION**

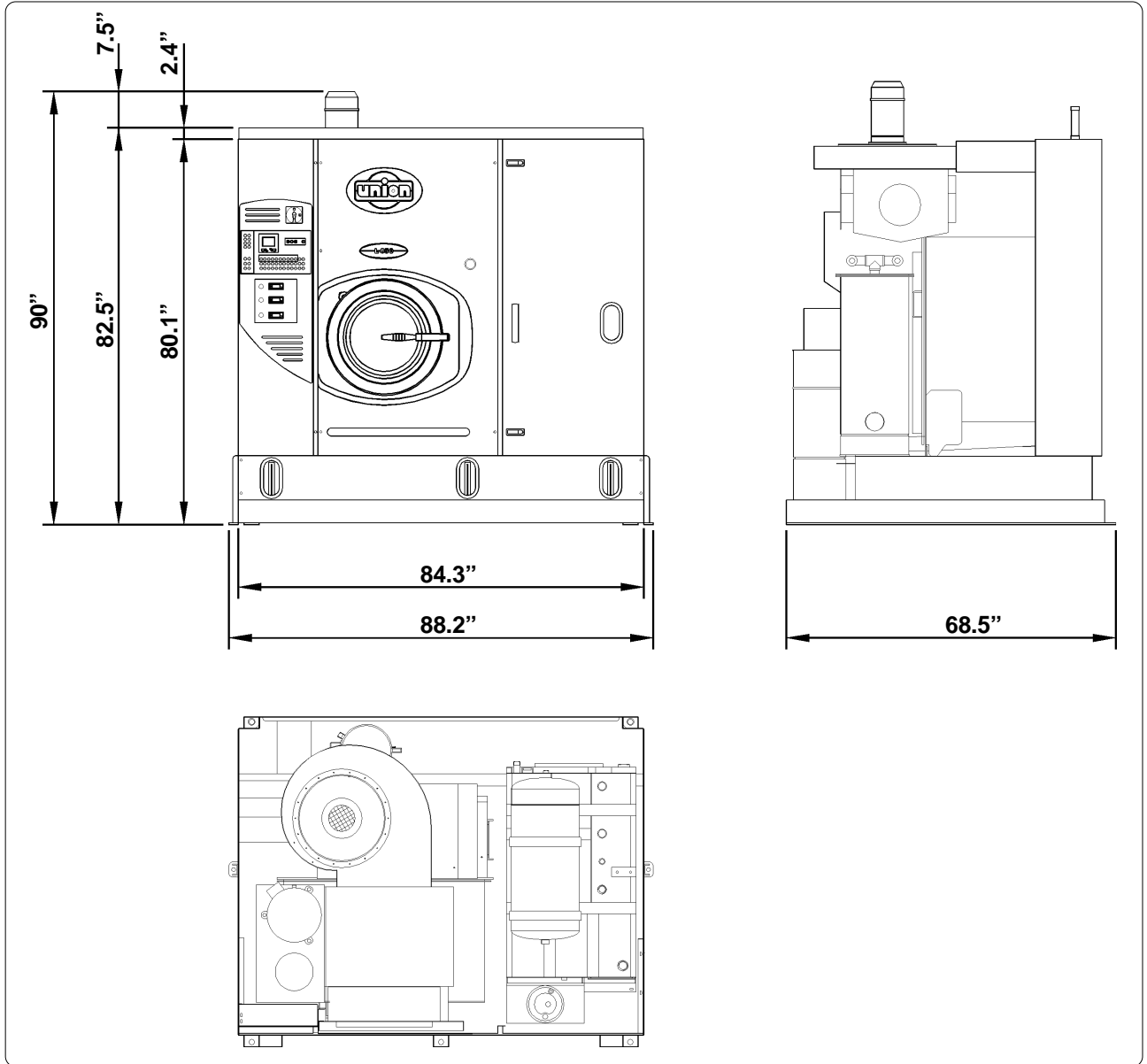

<b>CHARGES</b>		
Empty machine weight	Lbs	5093
Machine weight with solvent	Lbs	7628
Static charge on the floor with solvent	Lbs/ft <sup>2</sup>	190
Dynamic charge on the floor (+10%)	Lbs/ft <sup>2</sup>	233

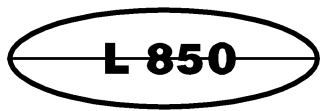

**PACKAGED MACHINE DIMENSIONS AND WEIGHTS**

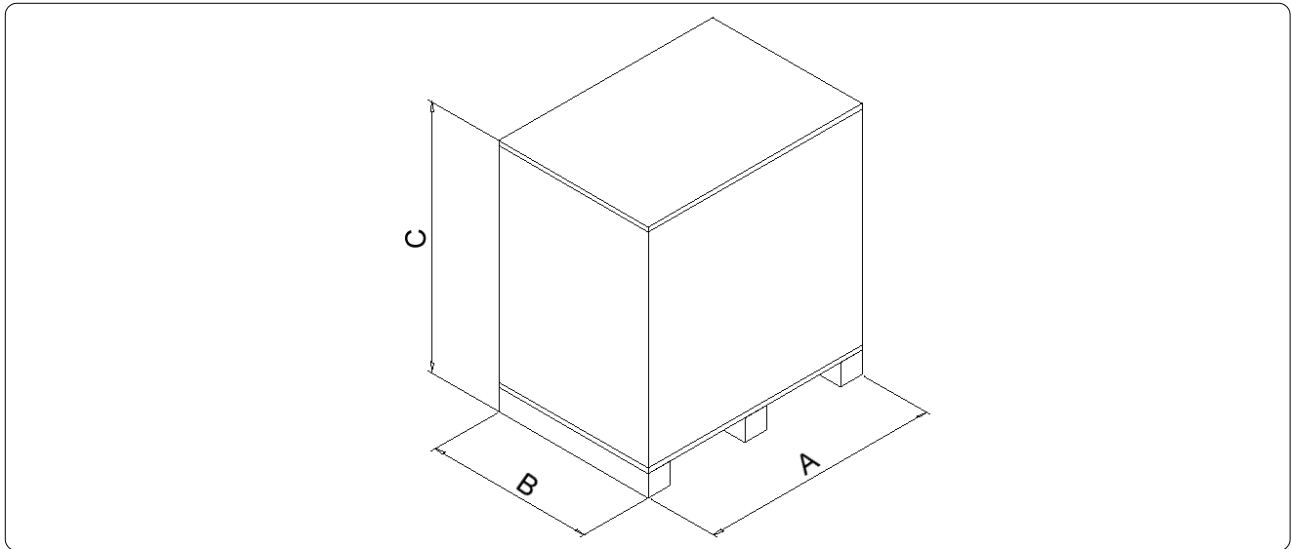

<b>PACKAGED MACHINE DIMENSIONS</b>				
Machine type		Carton	Wooden cage	Wooden case
<b>L850</b>	A	<b>inches 88.2"</b>	<b>inches 90.2"</b>	
	B	<b>inches 72.8"</b>	<b>inches 72.8"</b>	
	C	<b>inches 95.7"</b>	<b>inches 96.5"</b>	
<b>L850 U2000</b>	A	<b>inches 88.2"</b>	<b>inches 90.2"</b>	
	B	<b>inches 72.8"</b>	<b>inches 72.8"</b>	
	C	<b>inches 95.7"</b>	<b>inches 96.5"</b>	

<b>PACKAGED MACHINE WEIGHTS</b>			
Machine type	Carton	Wooden cage	Wooden case
<b>L850</b>	<b>Lbs 4565</b>	<b>Lbs 4940</b>	
<b>L850 U2000</b>	<b>Lbs 5270</b>	<b>Lbs 5490</b>	



FIXING POINTS - WITH FLOOR TANK

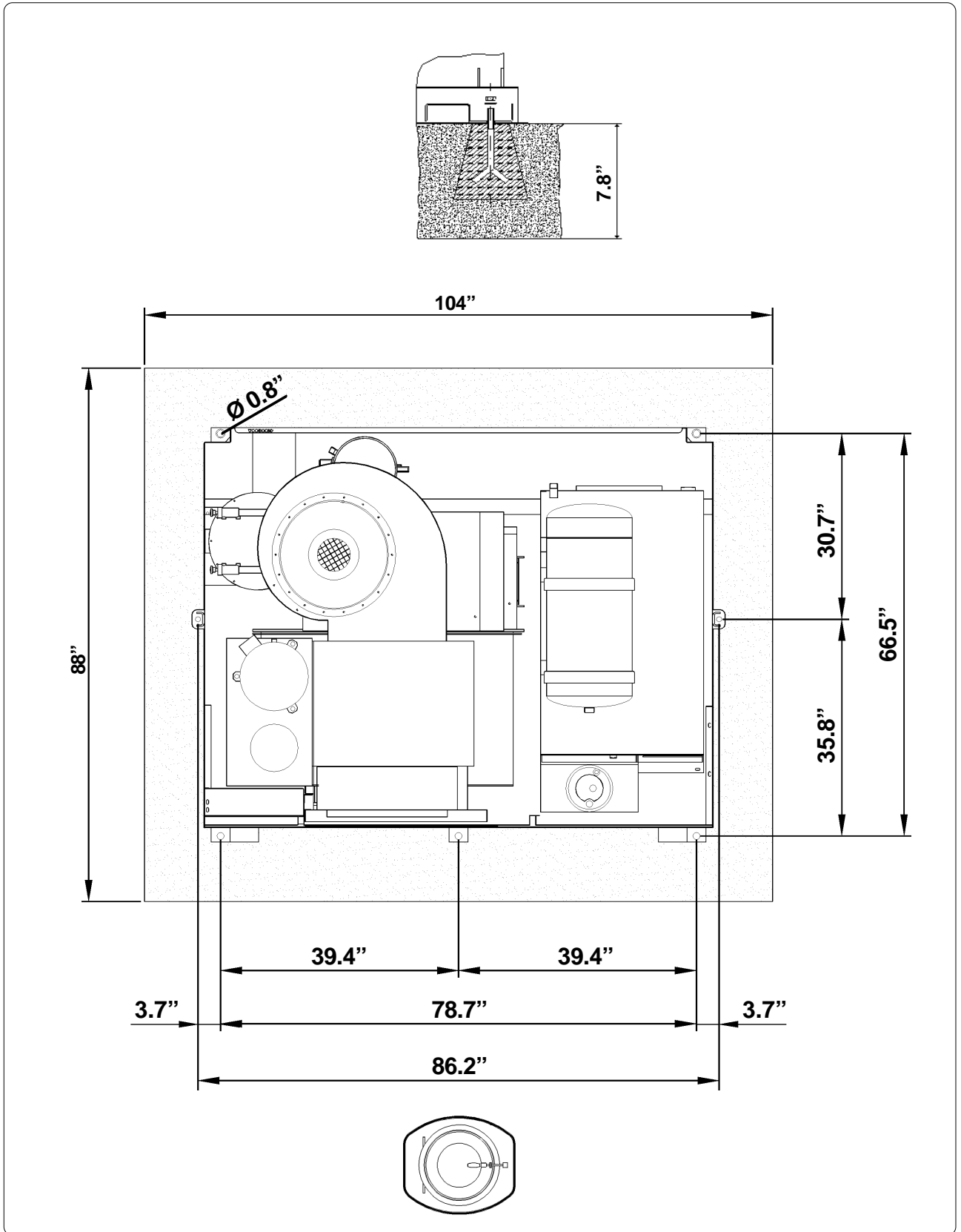





FIXING POINTS - WITHOUT FLOOR TANK

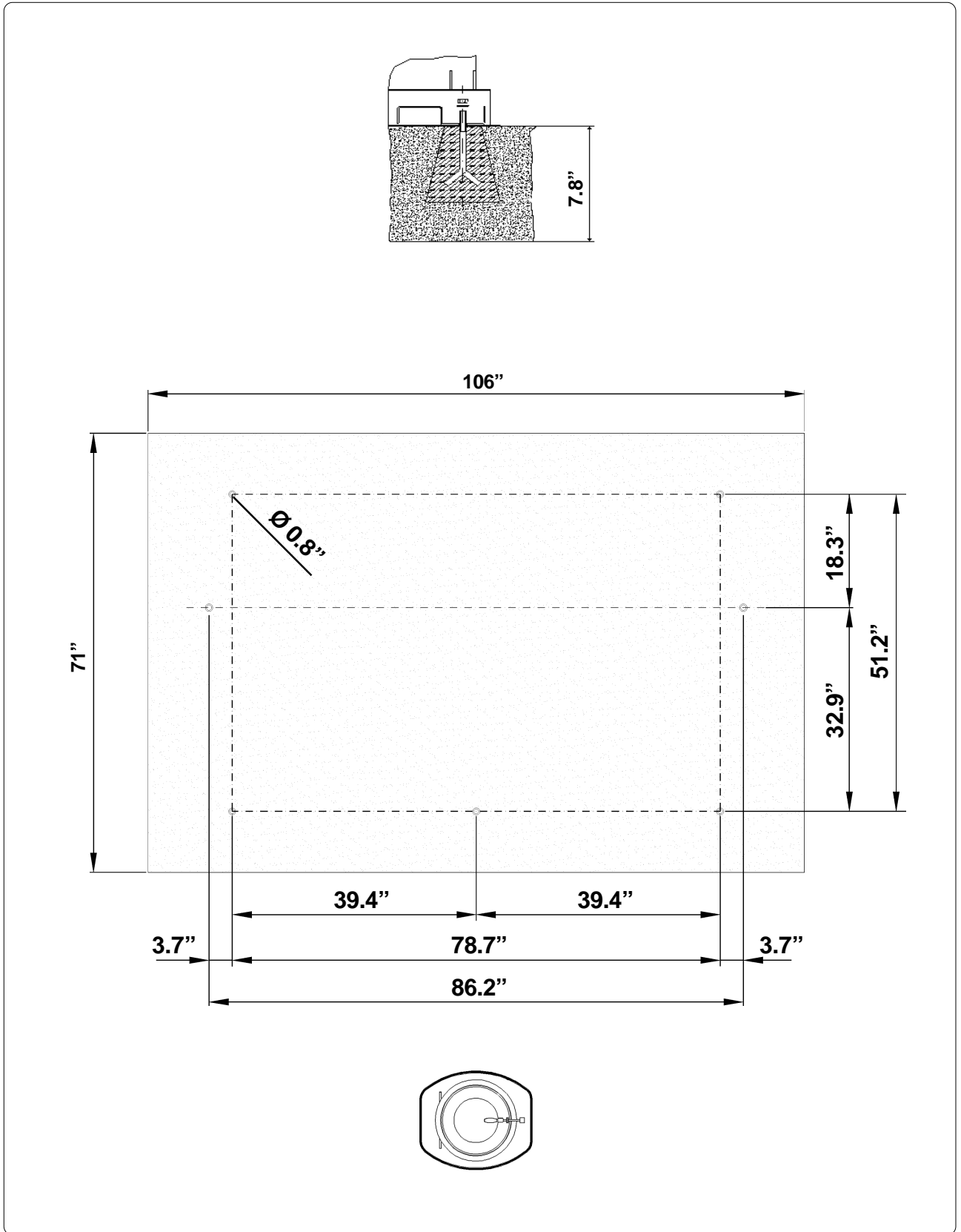

**CONNECTIONS**

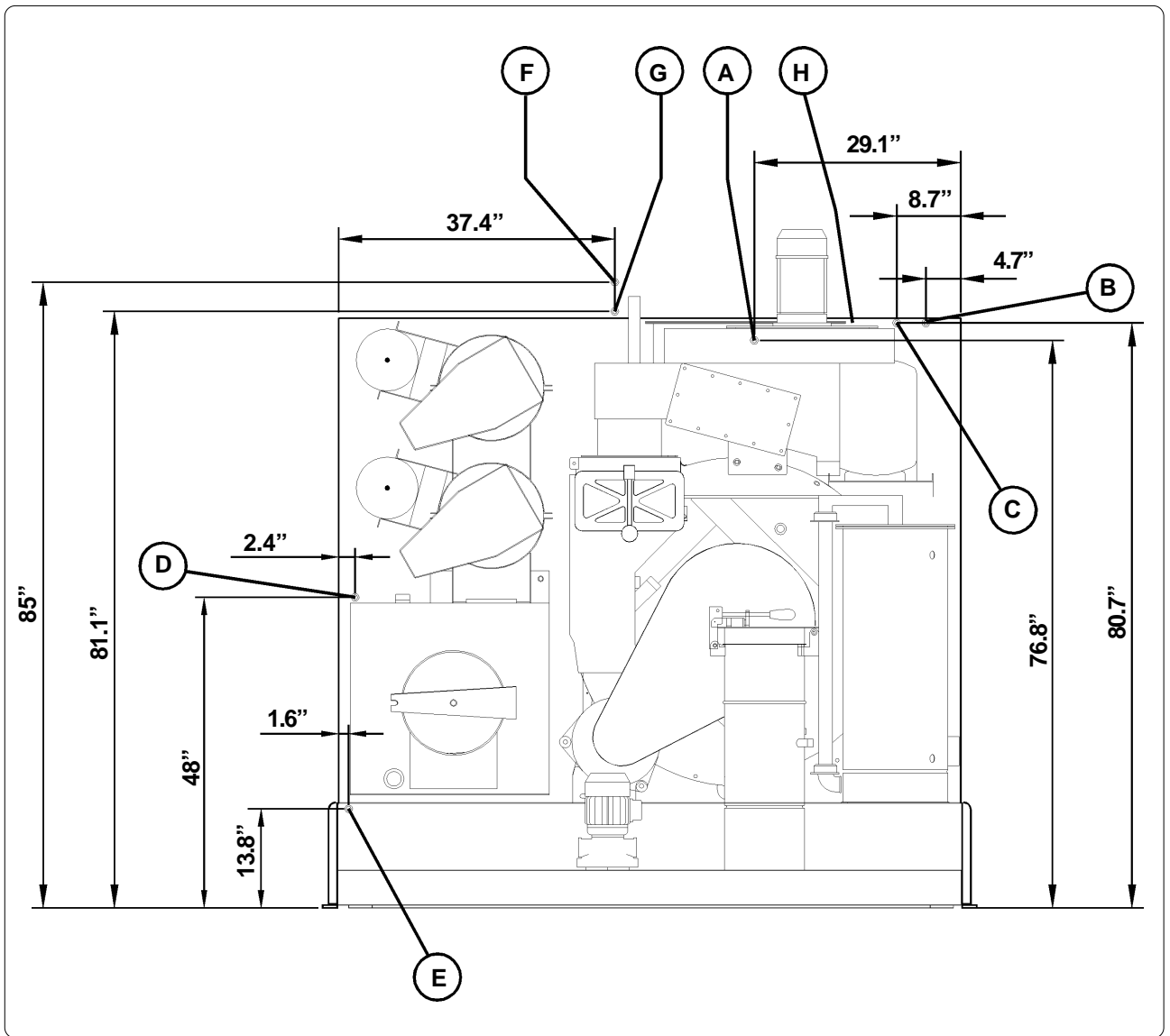

A	Compressed air inlet	mm 6
B	Water inlet	Ø 1"
C	Water outlet	Ø 1"
D	Steam still inlet	Ø 1/2"
E	Condensate still outlet	Ø 1/2"
F	Steam heater inlet	Ø 1/2"
G	Condensate heater outlet	Ø 1/2"
H	Electric connection	



SOLVENT TYPE		PERCHLOROETHYLENE		
NECESSARY QUANTITY OF SOLVENT TO FILL THE MACHINE				
Machine Version - 03	gal	157	Lbs	2094
Machine Version - 04	gal	180	Lbs	2403
Machine Version - 05	gal	177	Lbs	2359
Machine Version - 08	gal	164	Lbs	2183
Machine Version - 10	gal	186	Lbs	2491
Machine Version - 11	gal	184	Lbs	2447
Machine Version - 14	gal	190	Lbs	2535

INFORMATION FOR THE ELECTRICAL CONNECTIONS ( 220 V - 60 Hz )				
ELECTRIC Version with TURBO STILL	Kw	-	Amp	-
ELECTRIC Version without TURBO STILL	Kw	-	Amp	-
STEAM Version	Kw	9	Amp	58

GENERAL INFORMATION		
Required water capacity	gal/min	3
Required water pressure	psi	40 ÷ 70
Required water temperature	°F	65° ÷ 70°
Required air pressure	psi	100 ÷ 115
Required steam pressure (Steam Version)	psi	55 ÷ 70
Required steam availability (Steam Version)	Lbs/h	132