

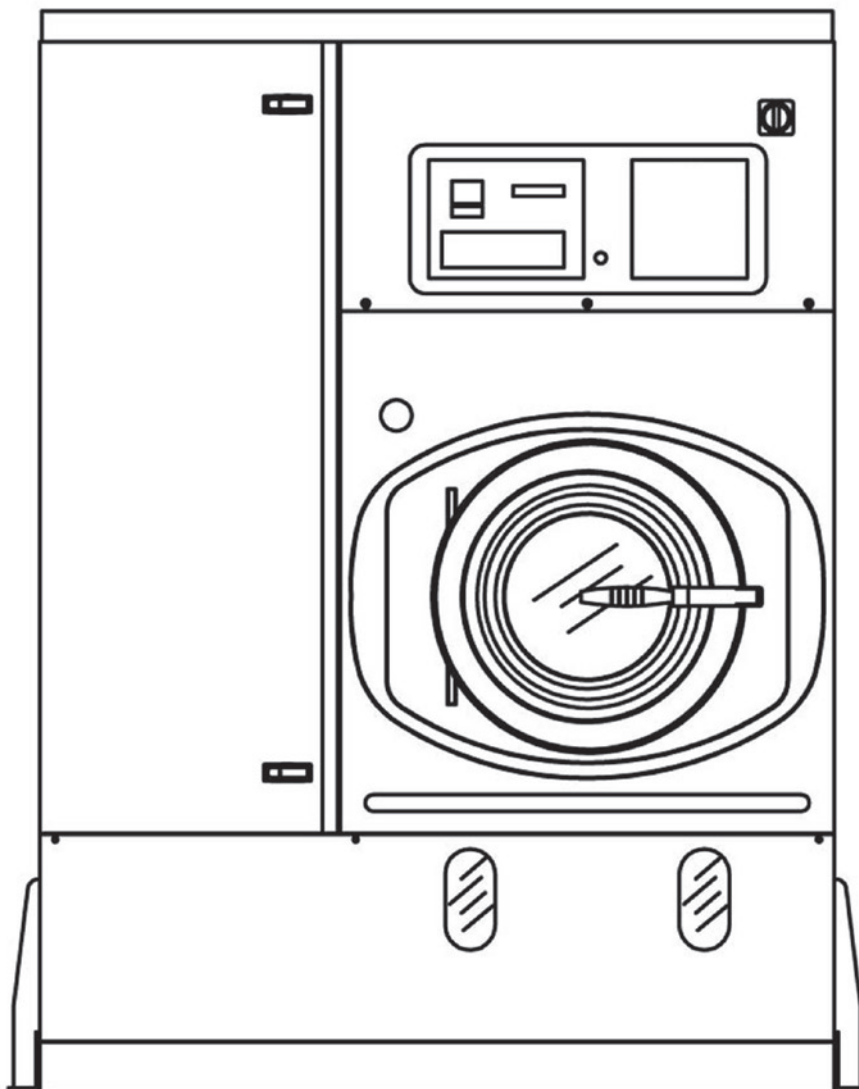

TECHNICAL INFORMATION



# NOVA 350E



WORKING MACHINE WITH SOLVENT	HYDROCARBON	
MACHINE CAPACITY	15 Kg	35 Lbs

BASKET		
Diameter	800 mm	31.5 inches
Depth	560 mm	22 inches
Volume	285 Lt	10.1 cu.ft
Wash speed	20 ÷ 55 rpm	
Extract speed	300 ÷ 520 rpm	
Door opening	500 mm	20 inches

SOLVENT TANKS		
Useful volume tank 1	105 Lt	28 gal
Useful volume tank 2	105 Lt	28 gal
Useful volume tank 3	-	-
FLOOR SAFETY TANK CAPACITY	210 Lt	55.5 gal

DECANTER FILTER		
Decanter filter	36 Lt	9.5 gal

ELECTRIC POWER	400V - 3~50Hz		220V - 3~60Hz	
	Wash - Extract (With Inverter)	*0.8÷4 Hp	*0.6÷3 Kw	*0.8÷4 Hp
Solvent pump motor 1	0.75 Hp	0.55 Kw	0.75 Hp	0.55 Kw
Solvent pump motor 2	0.75 Hp	0.55 Kw	0.75 Hp	0.55 Kw
Fan motor	2 Hp	1.5 Kw	2 Hp	1.5 Kw
Refrigerator compressor	3.35 Hp	2.5 Kw	3.35 Hp	2.5 Kw
Nylon filter motor	0.75 Hp	0.55 Kw	0.75 Hp	0.55 Kw
Remote Condenser	0.21 Hp	0.16 Kw	0.21 Hp	0.16 Kw
Air motor compressor (optional)	0.5 Hp	0.37 Kw	0.5 Hp	0.37 Kw

\* POWER CHANGES ACCORDINGLY TO THE USE OF THE MACHINE

NOTE: Acoustic emission level of the machine is lower than 70 dB (A)

**FILTRATION AVAILABLE IN THIS MODEL**
**ONE NYLON FILTER**

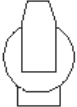
	Volume nylon filter housing	<b>55 Lt</b>	<i>14.5 gal</i>
	Nylon filter area	<b>3.9 mt<sup>2</sup></b>	<i>42 ft<sup>2</sup></i>
	Filter disks	<b>26 nr</b>	

**ONE NYLON FILTER AND ONE LARGE CARTRIDGE - KR**

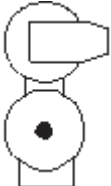
	Volume nylon filter housing	<b>55 Lt</b>	<i>14.5 gal</i>
	Nylon filter area	<b>3.9 mt<sup>2</sup></b>	<i>42 ft<sup>2</sup></i>
	Filter disks	<b>26 nr</b>	
	Vol. large cartridge housing KR	<b>55 Lt</b>	<i>14.5 gal</i>
	Area large cartridge KR	<b>2.6x2=5.2 mt<sup>2</sup></b>	<i>28x2=56 ft<sup>2</sup></i>
	Cartridges quantity KR	<b>nr 2</b>	



**DIMENSIONS AND WEIGHTS**

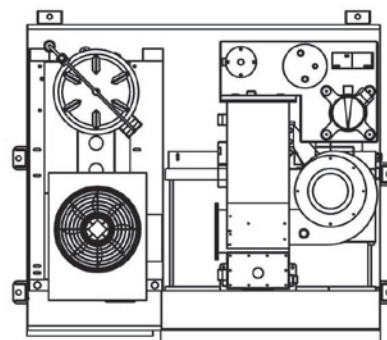
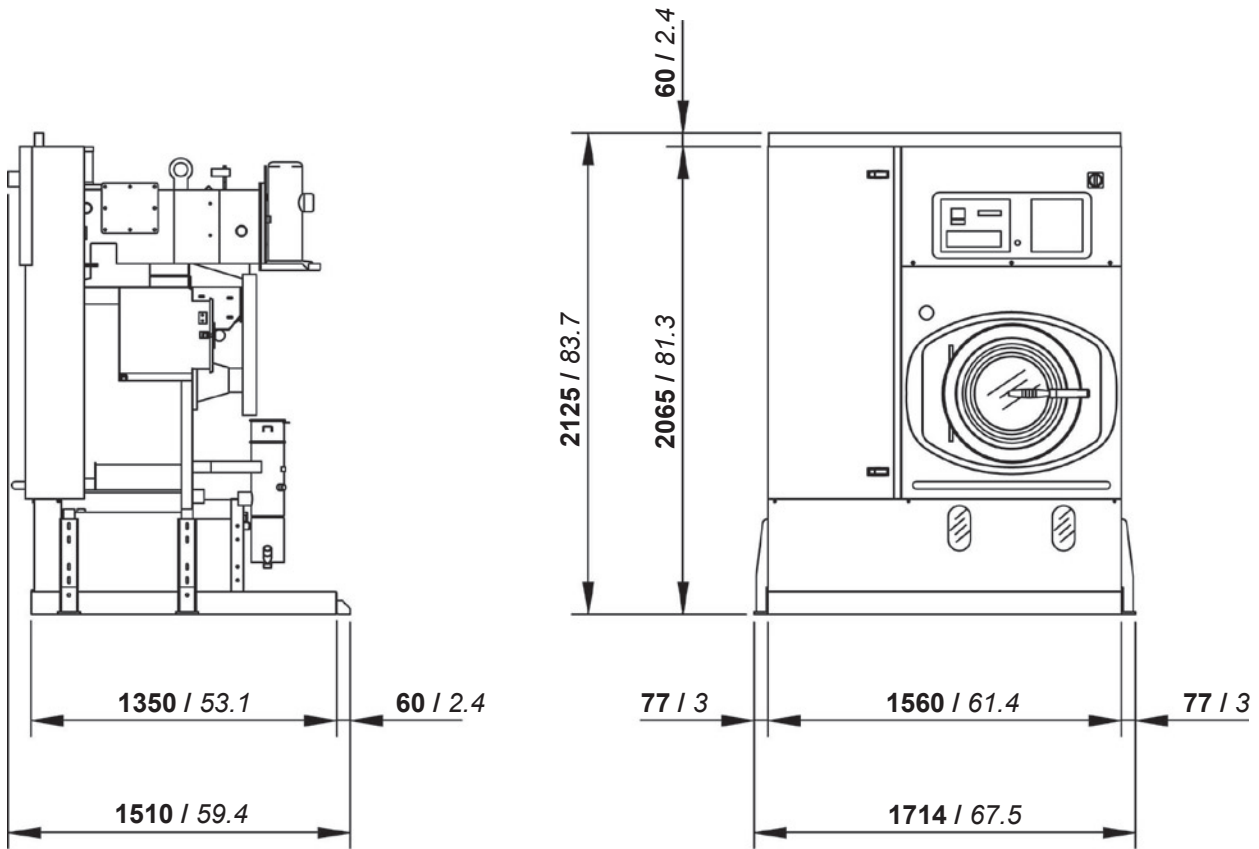

mm / inches

<b>CHARGES - STANDARD VERSION</b>		
Empty machine weight	<b>1120 Kg</b>	2469 Lbs
Machine weight with solvent	<b>1366 Kg</b>	3012 Lbs
Static charge on the floor with solvent	<b>649 Kg/m<sup>2</sup></b>	133 Lbs/ft <sup>2</sup>
Dynamic charge on the floor (+10%)	<b>1005 Kg/m<sup>2</sup></b>	206 Lbs/ft <sup>2</sup>



**PACKAGED MACHINE DIMENSIONS AND WEIGHTS**

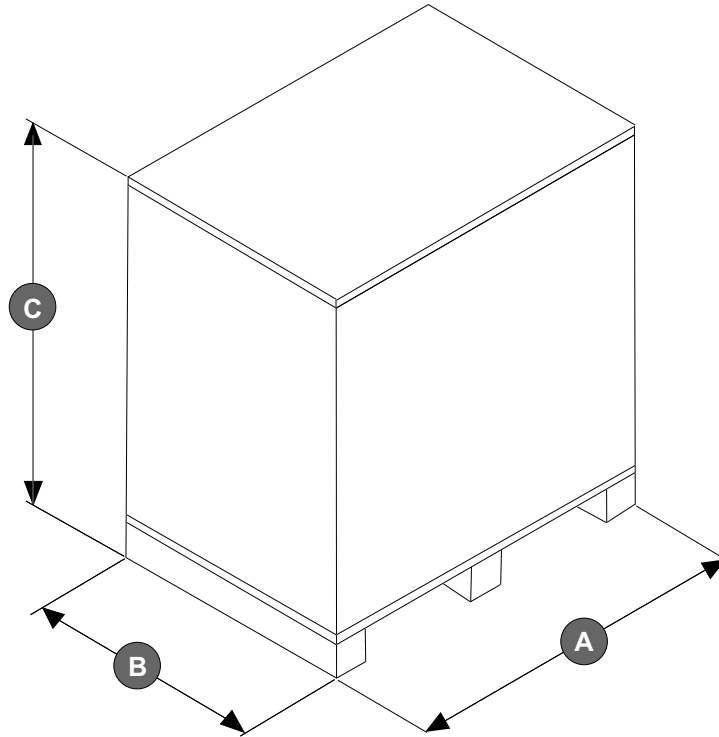

PACKAGED MACHINE DIMENSIONS							
Machine type		Carton		Wooden cage		Wooden case	
<b>Standard</b>	<b>A</b>	1760 mm	69.3 inches	- mm	- inches	- mm	- inches
	<b>B</b>	1580 mm	62.2 inches	- mm	- inches	- mm	- inches
	<b>C</b>	2245 mm	88.4 inches	- mm	- inches	- mm	- inches

PACKAGED MACHINE WEIGHTS						
Machine type	Carton		Wooden cage		Wooden case	
<b>Standard</b>	<b>1210 Kg</b>	<b>2668 Lbs</b>	<b>- Kg</b>	<b>- Lbs</b>	<b>- Kg</b>	<b>- Lbs</b>



FIXING POINTS WITH FLOOR TANK

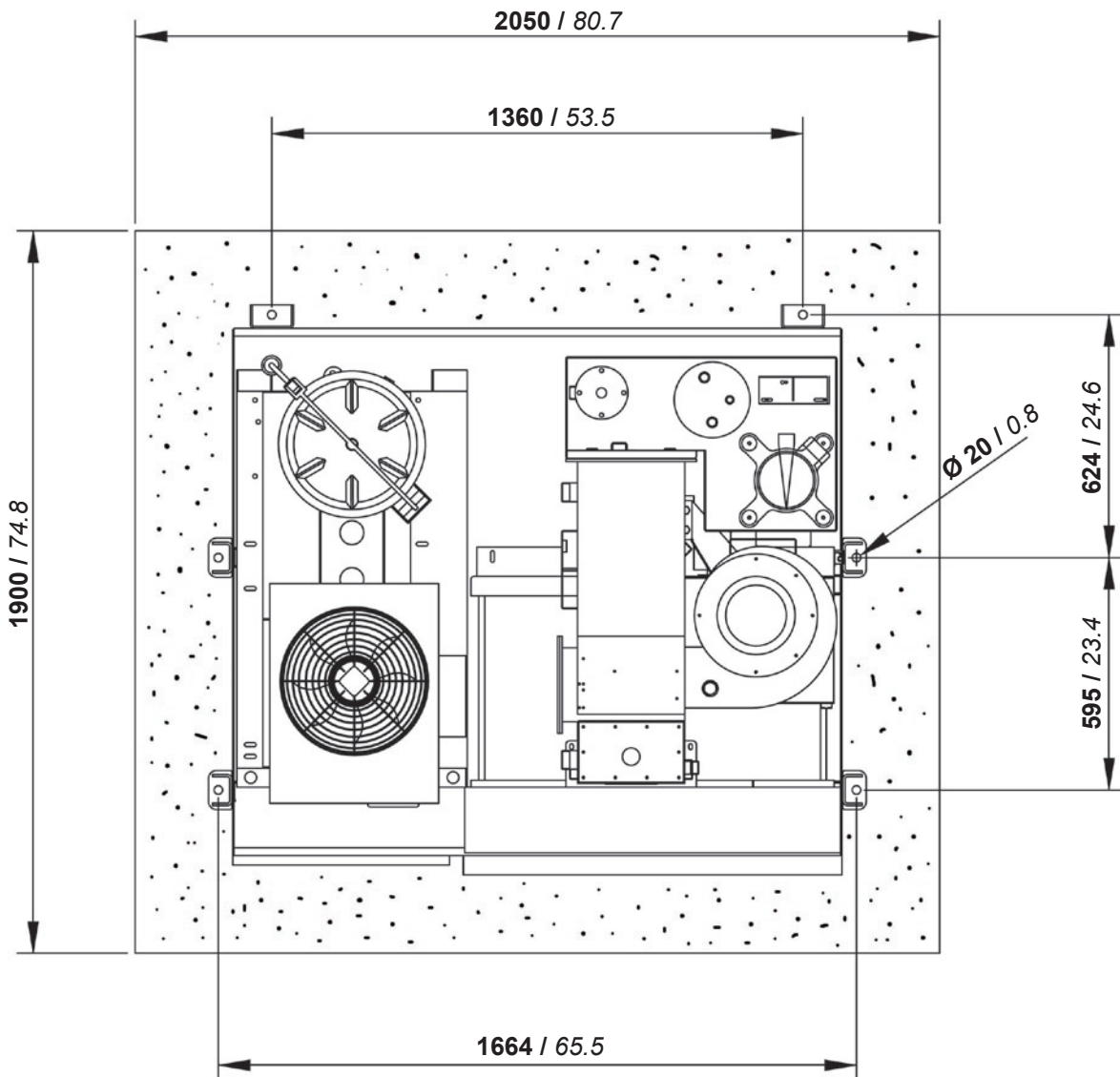
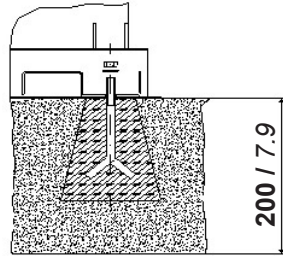

mm / inches



CONNECTIONS

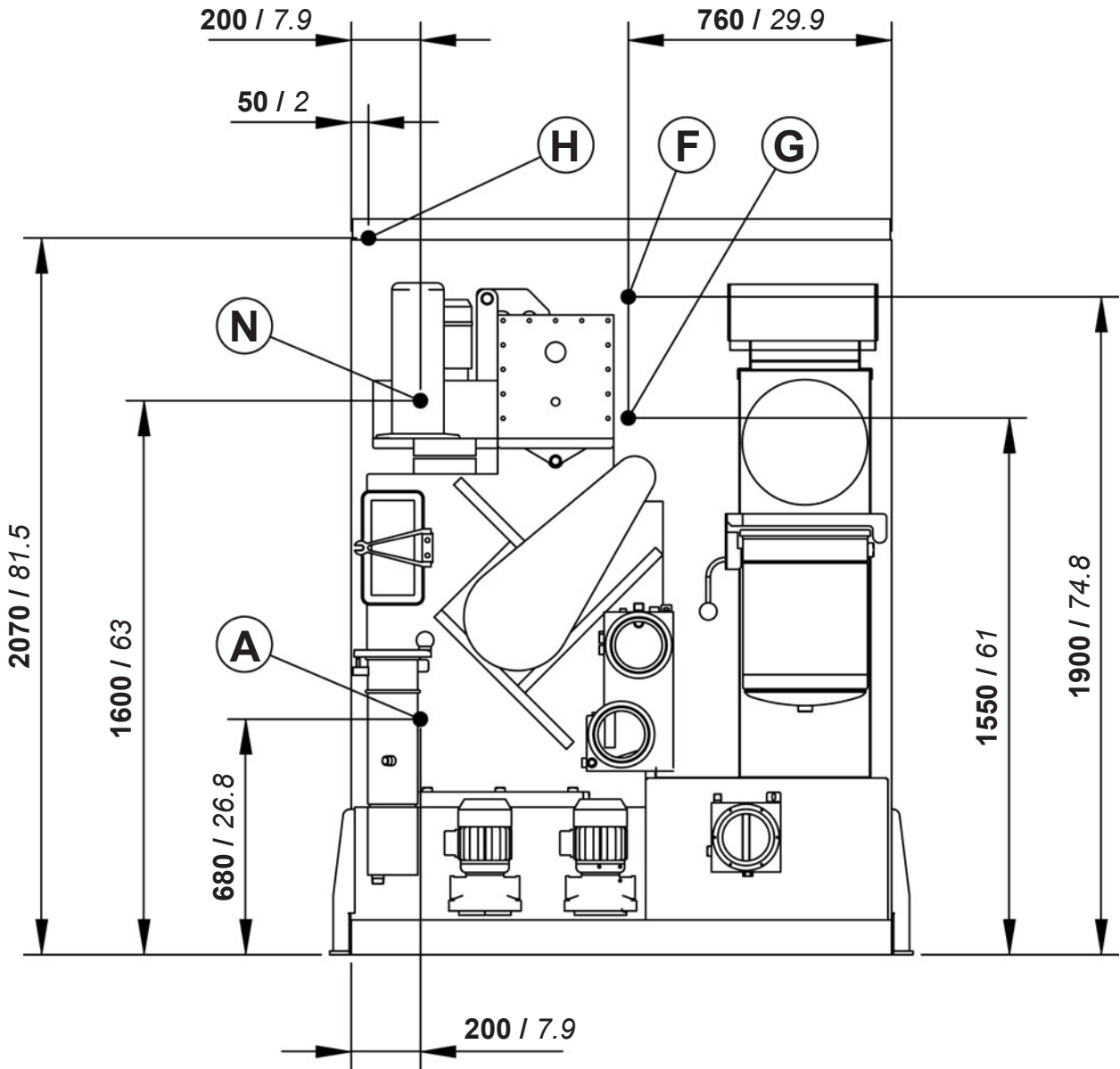

mm / inches

A	Compressed air inlet	mm 6	Ø 1/4"
B	-	-	-
C	-	-	-
D	-	-	-
E	-	-	-
F	Steam heater inlet (Opt.)	Ø 1/2"	
G	Condensate heater outlet (Opt.)	Ø 1/2"	
H	Electric connection		
N	Nitrogen feeding connection (N <sub>2</sub> )		



SOLVENT TYPE	HYDROCARBON			
NECESSARY QUANTITY OF SOLVENT TO FILL THE MACHINE				
Machine version - 1 Nylon Filter	265 Lt	204 Kg	70 gal	450 Lbs
Machine version - 1 Nylon Filter + 1 KR	320 Lt	246 Kg	85 gal	542 Lbs

INFORMATION FOR THE ELECTRICAL CONNECTIONS		(400V - 3~50Hz)	
STANDARD Version	6 Kw	12 Amp	
Dissipated heat	- Kcal		

INFORMATION FOR THE ELECTRICAL CONNECTIONS		(220V - 3~60Hz)	
STANDARD Version	6 Kw	25 Amp	
Dissipated heat	- Kcal		

GENERAL INFORMATION		
Required water capacity	Lt/min -	gal/min -
Required water pressure	bar -	psi -
Required water temperature	°C -	°F -
Required air pressure	bar 7 ÷ 8	psi 100 ÷ 115
Required steam pressure (Steam Version) (Opt.)	bar 4 ÷ 5	psi 55 ÷ 70
Required steam availability (Opt.)	Kg/h 15 ÷ 20	Lbs/h 33 ÷ 44

All technical data are subject to change without notice.