

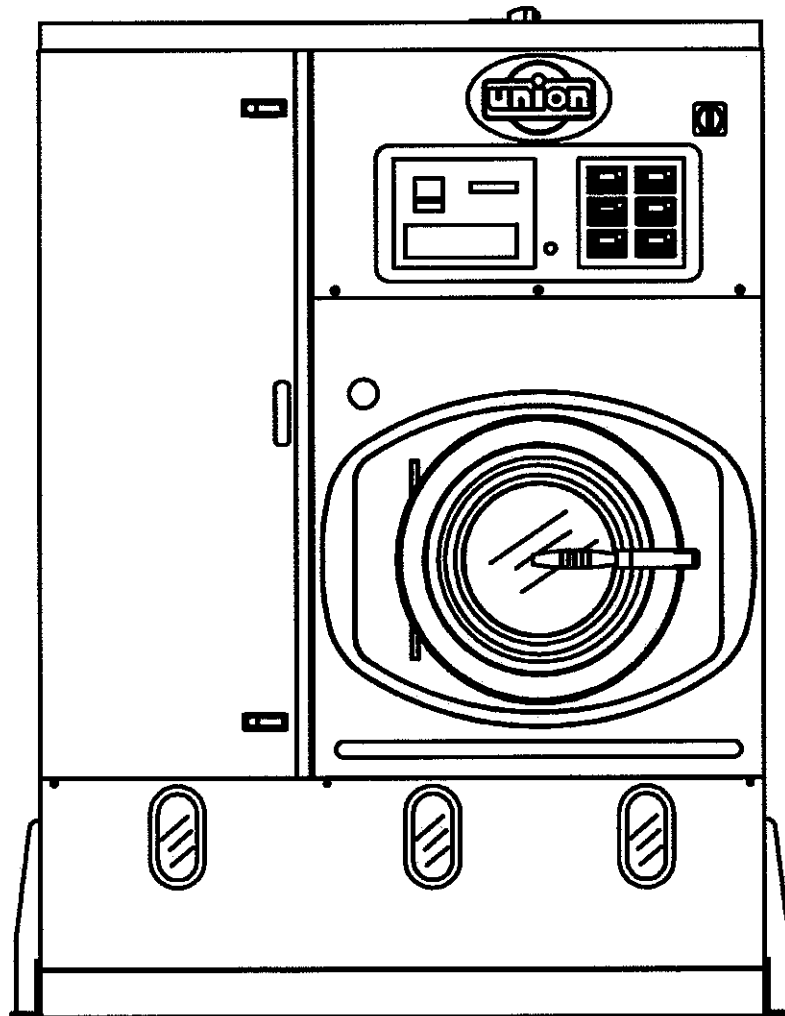

TECHNICAL INFORMATION



**XL 8015 S**



WORKING MACHINE WITH SOLVENT	PERCHLORETHYLENE	
MACHINE CAPACITY	15 Kg	35 Lbs

BASKET		
Diameter	800 mm	31.5 inches
Depth	560 mm	22 inches
Volume	285 Lt	10.1 cu.ft
Wash speed	20 ÷ 50 rpm	
Extract speed	300 ÷ 450 rpm	
Door opening	500 mm	19.7 inches

SOLVENT TANKS		
Useful volume tank 1	105 Lt	28 gal
Useful volume tank 2	105 Lt	28 gal
Useful volume tank 3	120 Lt	32 gal
<b>FLOOR SAFETY TANK CAPACITY</b>	<b>210 Lt</b>	<b>55.5 gal</b>

STILL		
Useful volume at half inspection	145 Lt	38.3 gal
Total volume	180 Lt	47.6 gal
Boiler water capacity	5.5 Lt	1.5 gal

ELECTRIC POWER	400V - 3~50Hz		220V - 3~60Hz	
	Wash - Extract (With Inverter)	*0.8÷4 Hp	*0.6÷3 Kw	*0.8÷4 Hp
Solvent pump motor	0.75 Hp	0.55 Kw	0.75 Hp	0.55 Kw
Fan motor	2 Hp	1.5 Kw	2 Hp	1.5 Kw
Refrigerator compressor (Bristoll)	3.35 Hp	2.5 Kw	3.35 Hp	2.5 Kw
Nylon filter motor	0.75 Hp	0.55 Kw	0.75 Hp	0.55 Kw
Sludge pump (optional)	0.75 Hp	0.55 Kw	0.75 Hp	0.55 Kw
Still electric elements	-	7.5 Kw	-	7.5 Kw
Heater electric elements	-	5.85 Kw	-	5.85 Kw
Air motor compressor (optional)	0.5 Hp	0.38 Kw	-	-
Fan motor Recuper 153 (optional)	0.75 Hp	0.55 Kw	0.75 Hp	0.55 Kw

\* POWER CHANGES ACCORDINGLY TO THE USE OF THE MACHINE

NOTE: Acoustic emission level of the machine is lower than 70 dB (A)



### FILTRATION AVAILABLE IN THIS MODEL

ONE NYLON FILTER			
	Volume nylon filter housing	<b>35 Lt</b>	<i>9.2 gal</i>
	Nylon filter area	<b>2.1 mt²</b>	<i>22.6 ft²</i>
	Filter disks	<b>14 nr</b>	

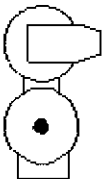
ONE NYLON FILTER AND ONE LARGE CARTRIDGE - KR			
	Volume nylon filter housing	<b>35 Lt</b>	<i>9.2 gal</i>
	Nylon filter area	<b>2.1 mt²</b>	<i>22.6 ft²</i>
	Filter disks	<b>14 nr</b>	
	Vol. large cartridge housing KR	<b>35 Lt</b>	<i>9.2 gal</i>
	Area large cartridge KR	<b>2.6 mt²</b>	<i>28 ft²</i>
	Cartridges quantity KR	<b>nr 1</b>	

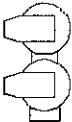
TWO NYLON FILTER			
	Volume nylon filter housing	<b>35x2=70 Lt</b>	<i>9.2x2=18.4 gal</i>
	Nylon filter area	<b>2.1x2=4.2 mt²</b>	<i>22.6x2=45.2 ft²</i>
	Filter disks	<b>14x2=28 nr</b>	

TWO NYLON FILTER AND ONE DECOLORATING FILTER PR			
	Volume nylon filter housing	<b>35x2=70 Lt</b>	<i>9.2x2=18.4 gal</i>
	Nylon filter area	<b>2.1x2=4.2 mt²</b>	<i>22.6x2=45.2 ft²</i>
	Filter disks	<b>14x2=28 nr</b>	
	Decolorating housing volume PR	<b>13 Lt</b>	<i>3,4 gal</i>
	Decolorating cartridges	<b>1 nr</b>	
	Decolorating cabon quantity	<b>2 kg</b>	<i>4,4 Lbs</i>



### DIMENSIONS AND WEIGHTS

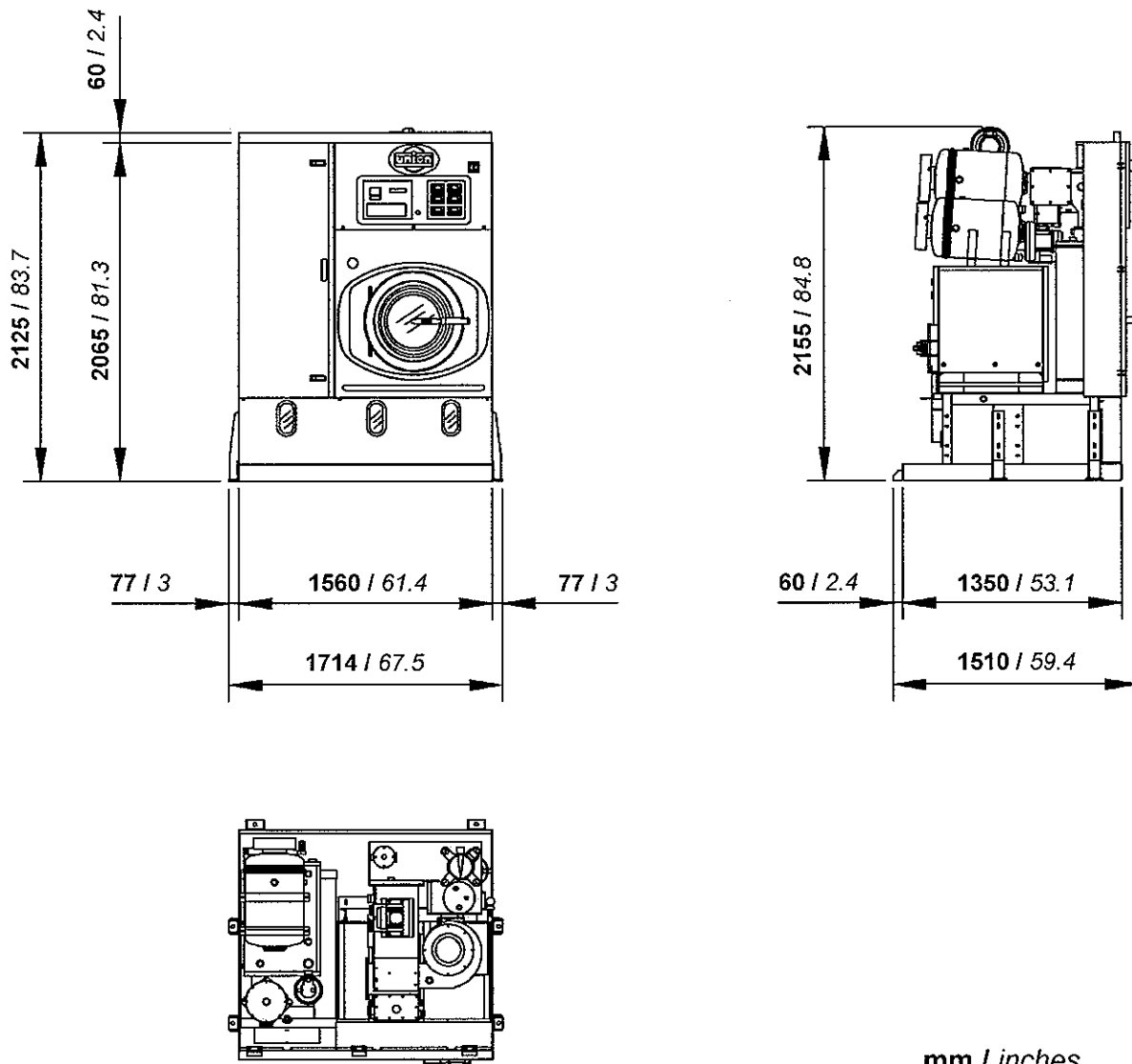

mm / inches

CHARGES - STANDARD VERSION		
Empty machine weight	1160 Kg	2557 Lbs
Machine weight with solvent	1832 Kg	4039 Lbs
Static charge on the floor with solvent	870 Kg/m <sup>2</sup>	178 Lbs/ft <sup>2</sup>
Dynamic charge on the floor (+10%)	1130 Kg/m <sup>2</sup>	231 Lbs/ft <sup>2</sup>
CHARGES - U2000 VERSION		
Empty machine weight	1240 Kg	2734 Lbs
Machine weight with solvent	1912 Kg	4215 Lbs
Static charge on the floor with solvent	908 Kg/m <sup>2</sup>	186 Lbs/ft <sup>2</sup>
Dynamic charge on the floor (+10%)	1170 Kg/m <sup>2</sup>	240 Lbs/ft <sup>2</sup>



### PACKAGED MACHINE DIMENSIONS AND WEIGHTS

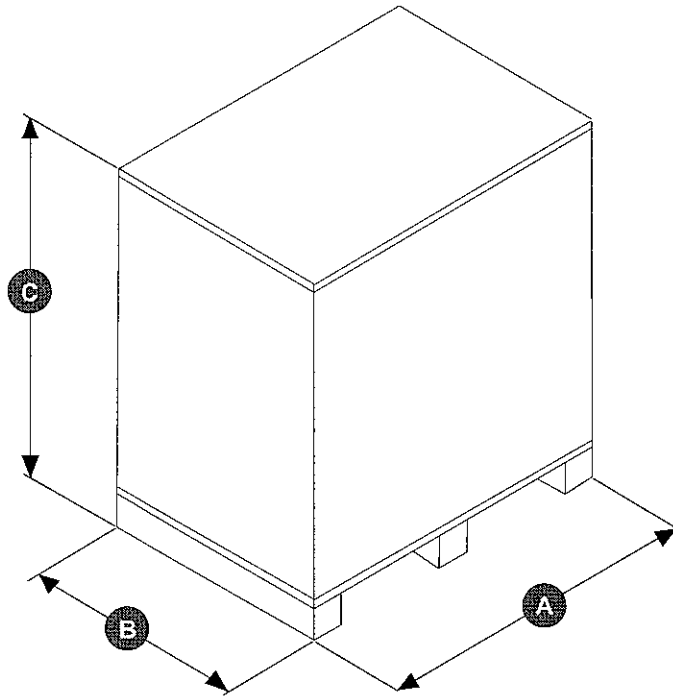

PACKAGED MACHINE DIMENSIONS							
Machine type		Carton		Wooden cage		Wooden case	
Standard	A	1760 mm	69.3 inches	- mm	- inches	- mm	- inches
	B	1580 mm	62.2 inches	- mm	- inches	- mm	- inches
	C	2245 mm	88.4 inches	- mm	- inches	- mm	- inches
U2000	A	1760 mm	69.3 inches	- mm	- inches	- mm	- inches
	B	1580 mm	62.2 inches	- mm	- inches	- mm	- inches
	C	2245 mm	88.4 inches	- mm	- inches	- mm	- inches

PACKAGED MACHINE WEIGHTS							
Machine type		Carton		Wooden cage		Wooden case	
Standard		1250 Kg	2756 Lbs	- Kg	- Lbs	- Kg	- Lbs
U2000		1310 Kg	2888 Lbs	- Kg	- Lbs	- Kg	- Lbs



FIXING POINTS

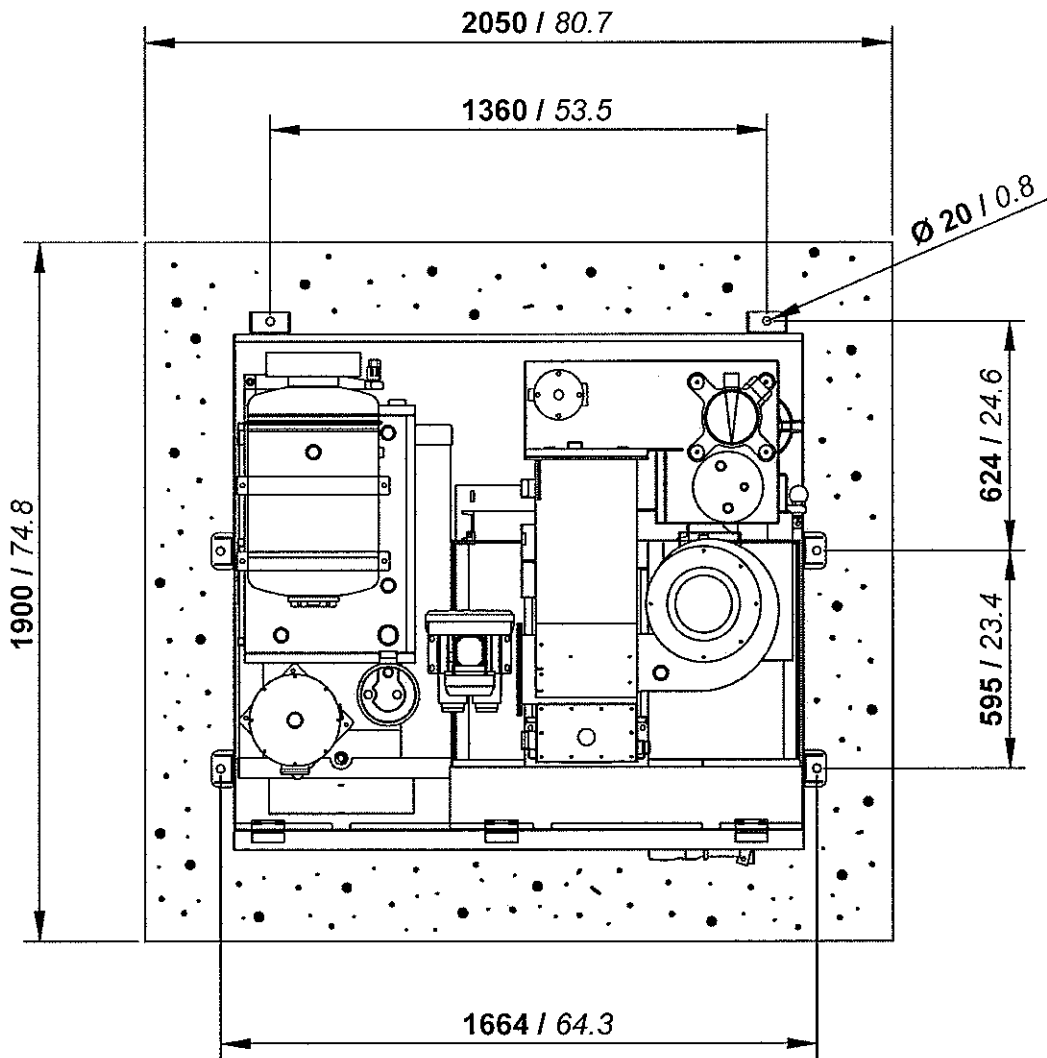
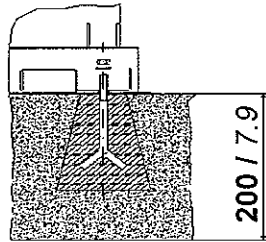

mm / inches

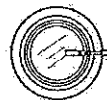



CONNECTIONS

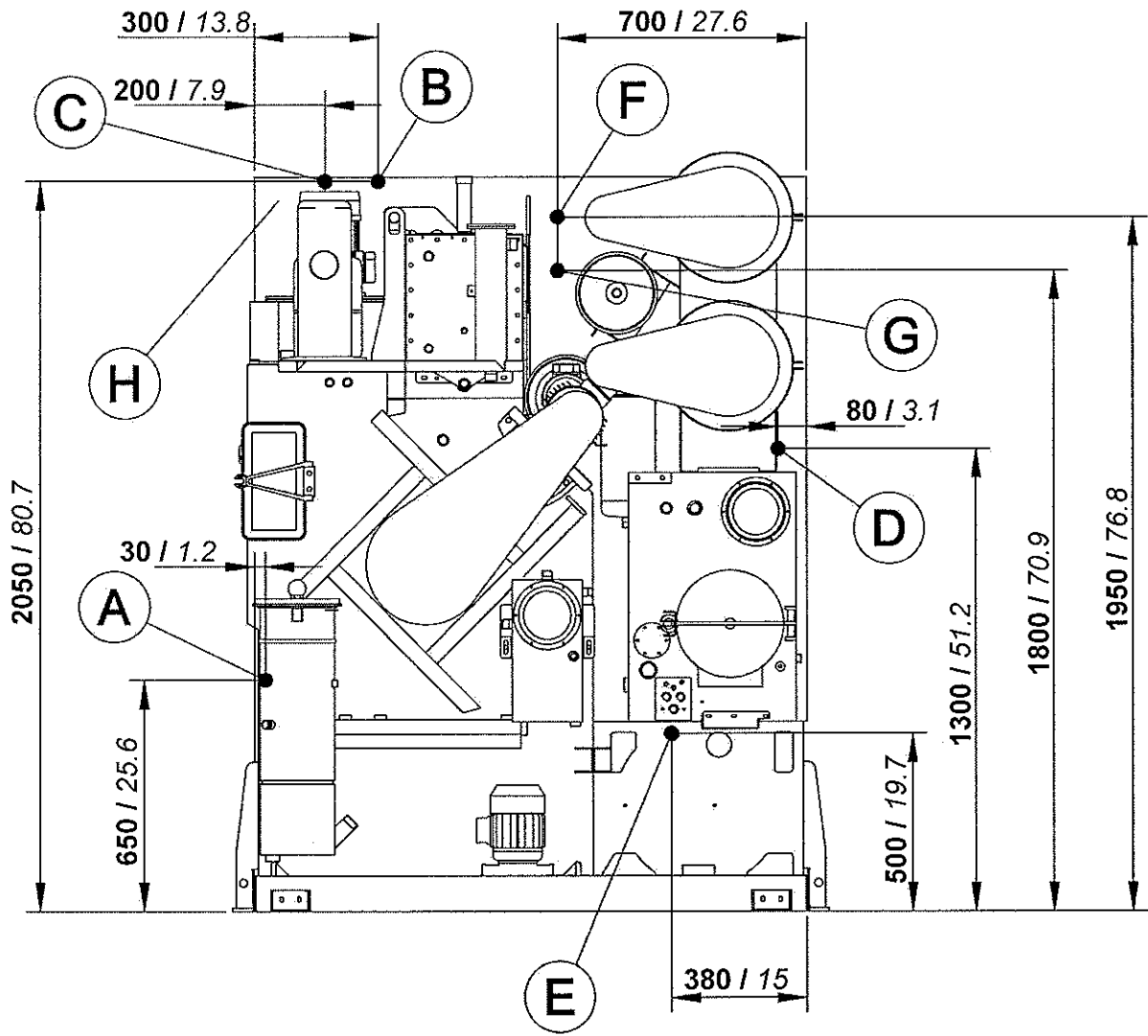

mm / inches

A	Compressed air inlet	mm 6	Ø 1/4"
B	Water inlet		Ø 3/4"
C	Water outlet		Ø 3/4"
D	Steam still inlet		Ø 1/2"
E	Condensate still outlet		Ø 1/2"
F	Steam heater inlet		Ø 1/2"
G	Condensate heater outlet		Ø 1/2"
H	Electric connection		



SOLVENT TYPE	PERCHLOROETHYLENE			
NECESSARY QUANTITY OF SOLVENT TO FILL THE MACHINE				
Machine version - without Filters	330 Lt	528 Kg	87.5 gal	1064 Lbs
Machine version - 1 Nylon Filter	365 Lt	584 Kg	96.5 gal	1287 Lbs
Machine version - 1 Nylon Filter + 1 KR	400 Lt	640 Kg	106 gal	1411 Lbs
Machine version - 2 Nylon Filters	400 Lt	640 Kg	106 gal	1411 Lbs
Machine version - 1 Nylon Filter + 1 Deco	378 Lt	605 Kg	100 gal	1334 Lbs

INFORMATION FOR THE ELECTRICAL CONNECTIONS (400V - 3~50Hz)		
ELECTRIC Version	18 Kw	30 Amp
STEAM Version	5.5 Kw	12 Amp
Dissipated heat	3250 Kcal	

INFORMATION FOR THE ELECTRICAL CONNECTIONS (220V - 3~60Hz)		
ELECTRIC Version	18 Kw	62 Amp
STEAM Version	5.5 Kw	20 Amp
Dissipated heat	3250 Kcal	

GENERAL INFORMATION		
Required water capacity	Lt/min 10	gal/min 2.6
Required water pressure	bar 2 ÷ 3	psi 29 ÷ 44
Required water temperature	°C 18 ÷ 23	°F 65 ÷ 73
Required air pressure	bar 7 ÷ 8	psi 100 ÷ 115
Required steam pressure (Steam Version)	bar 4 ÷ 5	psi 55 ÷ 70
Required steam availability	Kg/h 40	Lbs/h 88

All technical data are subject to change without notice.