

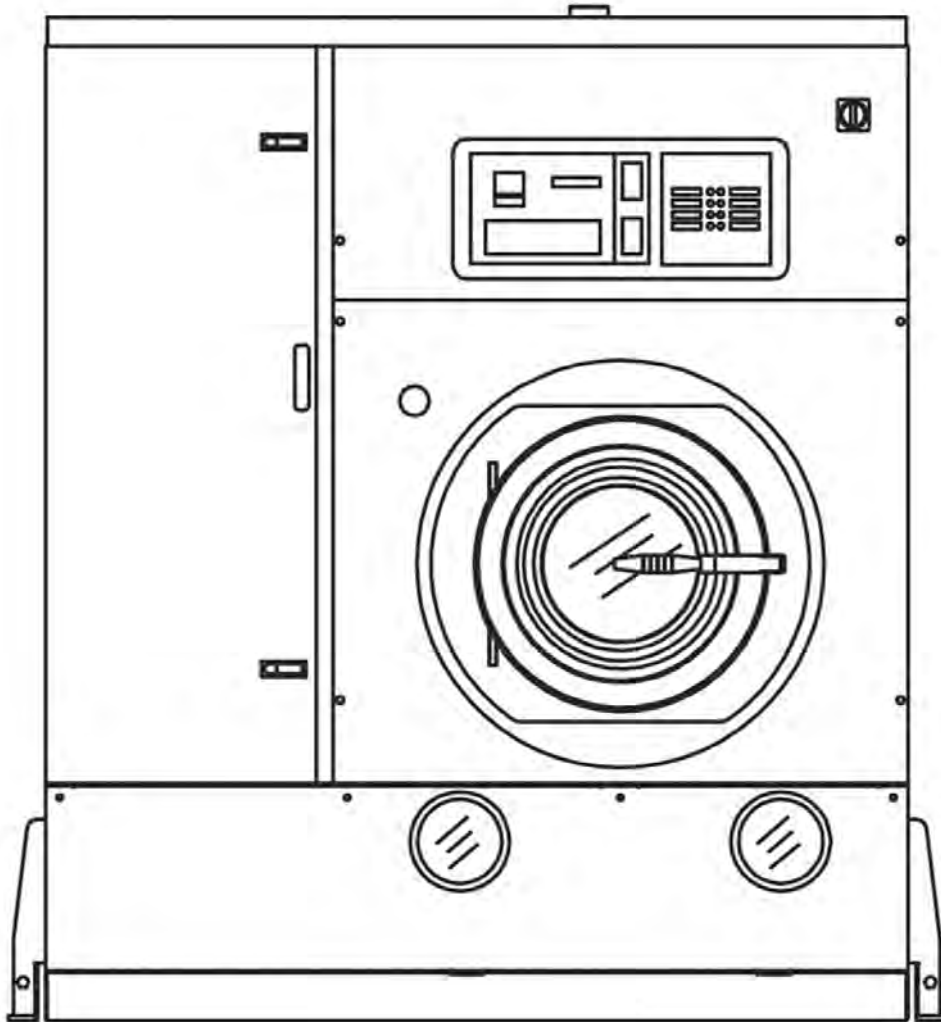

TECHNICAL INFORMATION



HXL 8018 C



MACHINE CAPACITY	18 Kg	40 Lbs
-------------------------	--------------	---------------

BASKET		
Diameter	900 mm	<i>35.4 inches</i>
Depth	535 mm	<i>21 inches</i>
Volume	340 Lt	<i>12 cu.ft</i>
Wash speed	20 ÷ 50 rpm	
Extract speed	300 ÷ 520 rpm	
Door opening	500 mm	<i>20 inches</i>

SOLVENT TANKS		
Useful volume tank 1	118 Lt	<i>31 gal</i>
Useful volume tank 2	118 Lt	<i>31 gal</i>
Useful volume tank 3	-	-
FLOOR SAFETY TANK CAPACITY	230 Lt	<i>61 gal</i>

ELECTRIC POWER	400V - 3~50Hz		220V - 3~60Hz	
Wash - Extract (With Inverter)	*1.7÷4.7 Hp	*1.3÷3.5 Kw	<i>*1.7÷4.7 Hp</i>	<i>*1.3÷3.5 Kw</i>
Solvent pump motor 1	1 Hp	0.75 Kw	<i>1 Hp</i>	<i>0.75 Kw</i>
Solvent pump motor 2 (Optional)	1 Hp	0.75 Kw	<i>1 Hp</i>	<i>0.75 Kw</i>
Fan motor	2 Hp	1.5 Kw	<i>3.5 Hp</i>	<i>2.65 Kw</i>
Refrigerator compressor	5.7 Hp	4.26 Kw	<i>7 Hp</i>	<i>5.26 Kw</i>
Remote Condenser (Optional)	0.21 Hp	0.16 Kw	<i>0.21 Hp</i>	<i>0.16 Kw</i>
Heater electric elements	-	9 Kw	-	<i>9 Kw</i>
Air motor compressor (Optional)	0.5 Hp	0.38 Kw	<i>0.5 Hp</i>	<i>0.38 Kw</i>

* POWER CHANGES ACCORDINGLY TO THE USE OF THE MACHINE

NOTE: Acoustic emission level of the machine is lower than 70 dB (A)



FILTRATION AVAILABLE IN THIS MODEL

3 LARGE CARTRIDGE - KR (2 filter unit)			
	Vol. large cartridge housing KR	105x3=315 Lt	<i>27.8x3=83.4 gal</i>
	Area large cartridge KR	2.6x12=31.2 mt²	<i>28x12=336 ft²</i>
	Cartridges quantity KR	nr 4x3=12	



DIMENSIONS AND WEIGHTS

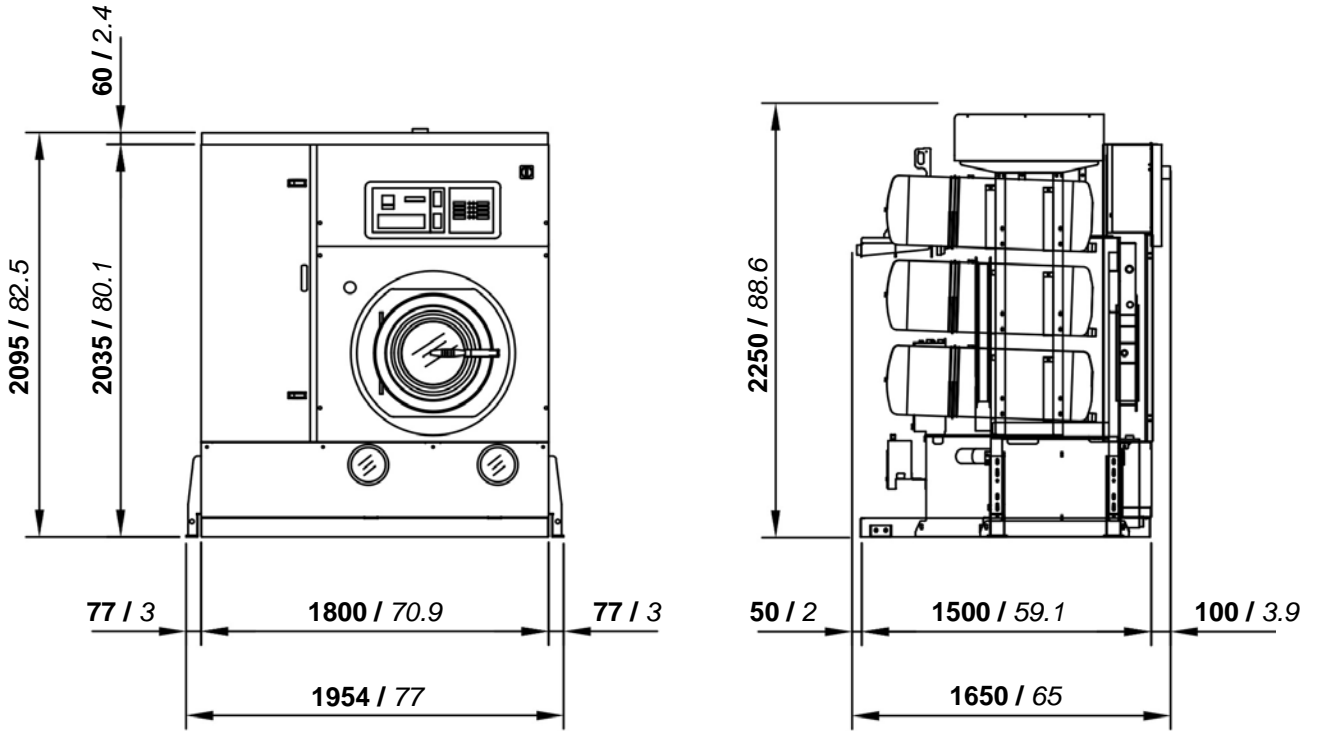

mm / inches

CHARGES		
Empty machine weight	1450 Kg	3197 Lbs
Machine weight with solvent	1874 Kg	34131 Lbs
Static charge on the floor with solvent	694 Kg/m²	142 Lbs/ft²
Dynamic charge on the floor (+10%)	1069 Kg/m²	219 Lbs/ft²



PACKAGED MACHINE DIMENSIONS AND WEIGHTS

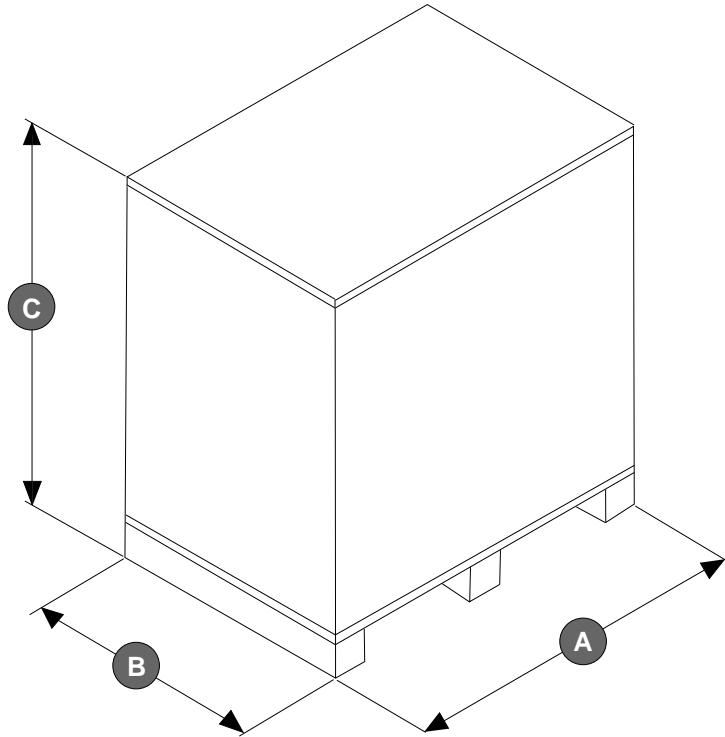

PACKAGED MACHINE DIMENSIONS							
Machine type		Carton		Wooden cage		Wooden case	
Standard	A	- mm	- inches	- mm	- inches	- mm	- inches
	B	- mm	- inches	- mm	- inches	- mm	- inches
	C	- mm	- inches	- mm	- inches	- mm	- inches

PACKAGED MACHINE WEIGHTS						
Machine type	Carton		Wooden cage		Wooden case	
Standard	- Kg	- Lbs	- Kg	- Lbs	- Kg	- Lbs



FIXING POINTS

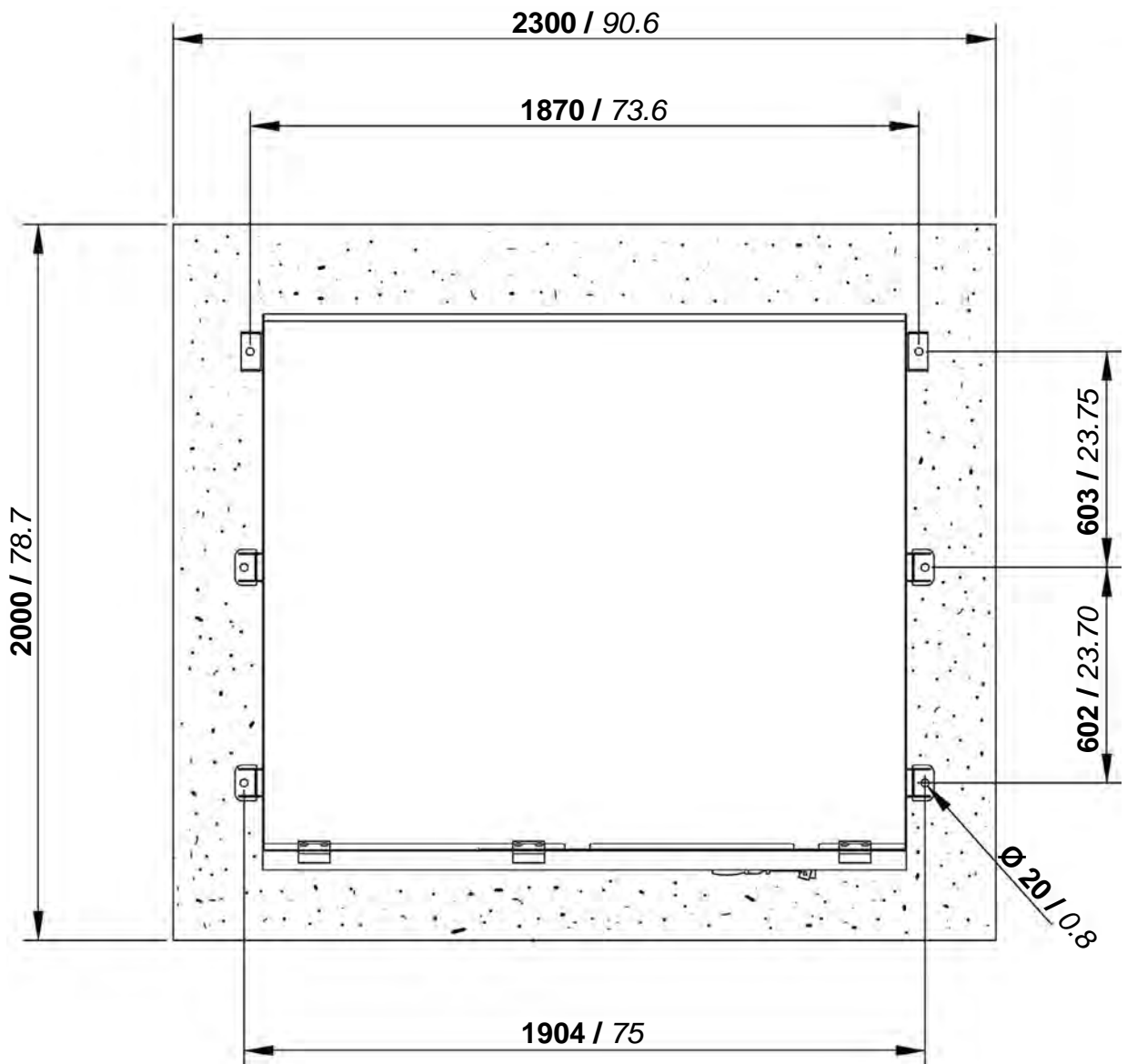
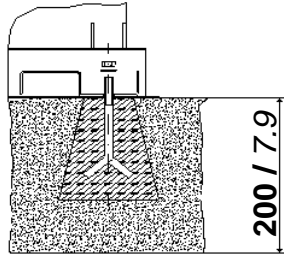

mm / inches





CONNECTIONS

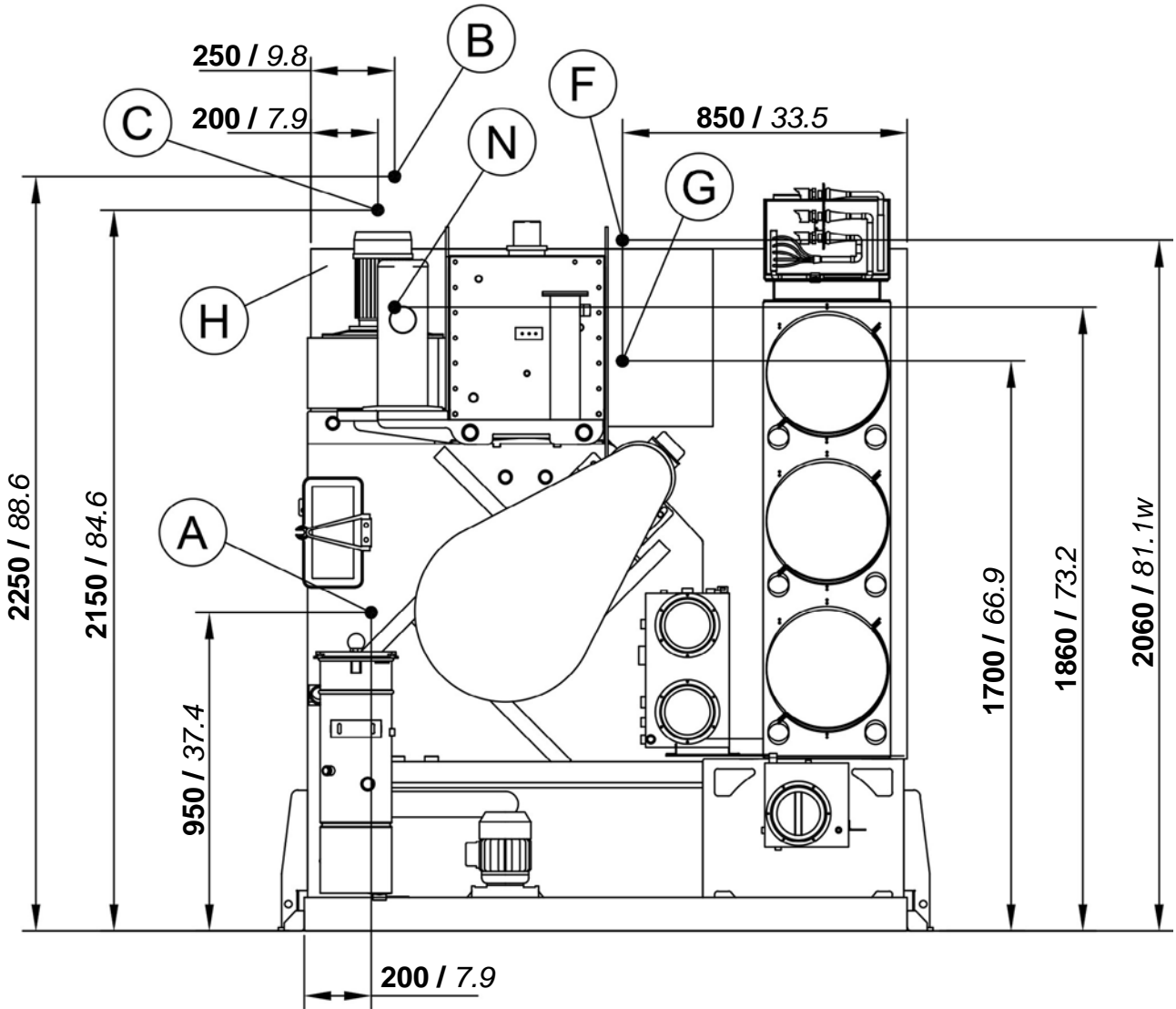

mm / inches

A	Compressed air inlet	Ø 6mm	Ø 1/4"
B	Water inlet (Opt.)	Ø 3/4"	
C	Water outlet (Opt.)	Ø 3/4"	
D	-	-	
E	-	-	
F	Steam heater inlet (Opt.)	Ø 1/2"	
G	Condensate heater outlet (Opt.)	Ø 1/2"	
H	Electric connection		
N	Nitrogen feeding connection (N ₂)		



NECESSARY QUANTITY OF SOLVENT TO FILL THE MACHINE				
Machine version - without Filters	236 Lt	182 Kg	<i>62 gal</i>	<i>401 Lbs</i>
Machine version - 3 KR Filters (2 Filter Unit)	551 Lt	424 Kg	<i>145 gal</i>	<i>935 Lbs</i>

INFORMATION FOR THE ELECTRICAL CONNECTIONS (400V - 3~50Hz)		
ELECTRIC Version	- Kw	- Amp
STEAM Version	7.5 Kw	16 Amp
Dissipated heat	- Kcal	

INFORMATION FOR THE ELECTRICAL CONNECTIONS (220V - 3~60Hz)		
ELECTRIC Version	- Kw	- Amp
STEAM Version	9 Kw	45 Amp
Dissipated heat	- Kcal	

GENERAL INFORMATION		
Required water capacity	10 Lt/min	<i>2.6 gal/min</i>
Required water pressure	2 ÷ 3 bar	<i>29 ÷ 44 psi</i>
Required water temperature	18 ÷ 23 °C	<i>65 ÷ 73 °F</i>
Required air pressure	7 ÷ 8 bar	<i>100 ÷ 115 psi</i>
Required steam* pressure (Steam Version)	3.5 ÷ 4 bar	<i>51 ÷ 58 psi</i>
Required steam* availability (Steam Version)	15 ÷ 20 Kg/h	<i>33 ÷ 44 Lbs/h</i>

* Relative values of dry saturated steam.

All technical data are subject to change without notice.