

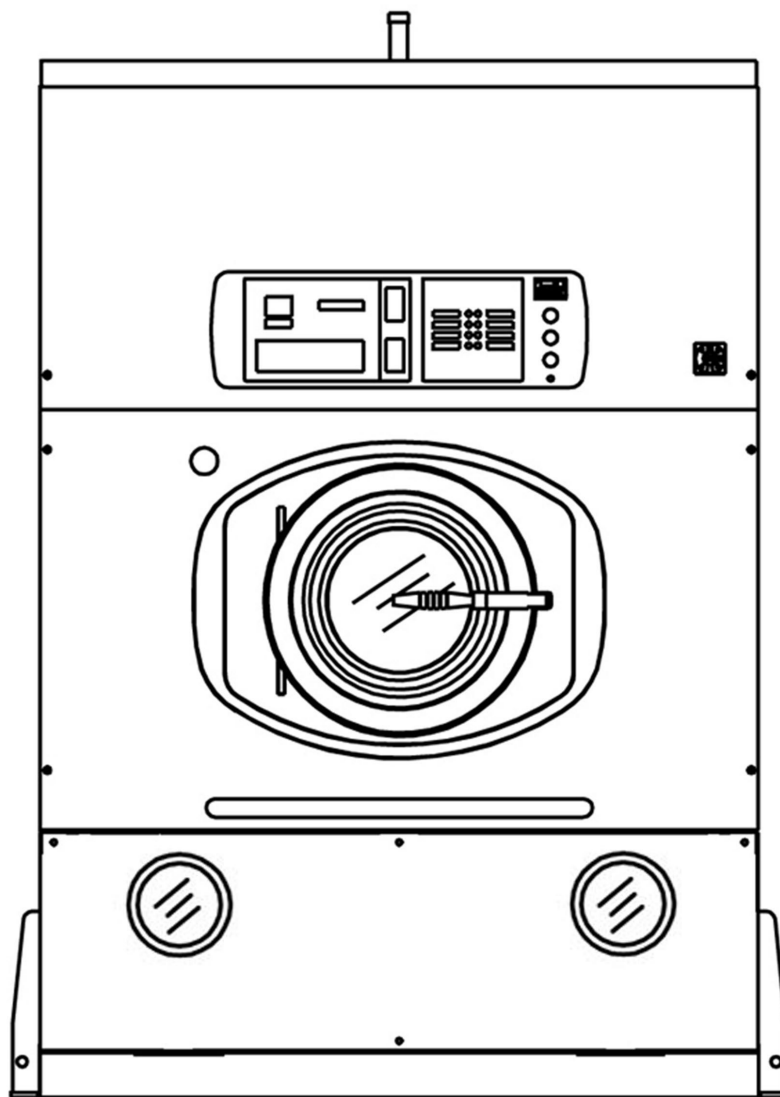

TECHNICAL INFORMATION



M-HXL8032-K
MULTISOLVENT

M2



MACHINE CAPACITY	32 Kg	70÷80 Lbs
-------------------------	--------------	------------------

BASKET		
Diameter	1200 mm	<i>47.3 inches</i>
Depth	570 mm	<i>22.5 inches</i>
Volume	645 Lt	<i>22.8 cu.ft</i>
Wash speed	20 ÷ 50 rpm	
Extract speed	300 ÷ 450 rpm	
Door opening	500 mm	<i>20 inches</i>

SOLVENT TANKS		
Useful volume tank 1	190 Lt	<i>50 gal</i>
Useful volume tank 2	190 Lt	<i>50 gal</i>
Useful volume tank 3	-	-
FLOOR SAFETY TANK CAPACITY	265 Lt	<i>70 gal</i>

ELECTRIC POWER	400V - 3~50Hz		220V - 3~60Hz	
Wash - Extract (With Inverter)	*8.1 Hp	*6.1 Kw	<i>*8.1 Hp</i>	<i>*6.1 Kw</i>
Solvent pump motor	1.5 Hp	1.1 Kw	<i>1.5 Hp</i>	<i>1.1 Kw</i>
Fan motor	4 Hp	3 Kw	<i>5.5 Hp</i>	<i>4.13 Kw</i>
Refrigerator compressor	7.5 Hp	5.66 Kw	<i>9.6 Hp</i>	<i>7.2 Kw</i>
Nylon filter motor	0.75 Hp	0.55 Kw	<i>0.75 Hp</i>	<i>0.55 Kw</i>
Heater electric elements	-	12 Kw	-	<i>12 Kw</i>
Air motor compressor (optional)	0.5 Hp	0.38 Kw	<i>0.5 Hp</i>	<i>0.38 Kw</i>

*** POWER CHANGES ACCORDINGLY TO THE USE OF THE MACHINE**

NOTE: Acoustic emission level of the machine is lower than 70 dB (A)

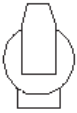

FILTRATION AVAILABLE IN THIS MODEL

ONE NYLON FILTER			
	Volume nylon filter housing	75 Lt	<i>20 gal</i>
	Nylon filter area	5.5 mt²	<i>59 ft²</i>
	Filter disks	39 nr	

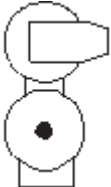
ONE NYLON FILTER AND ONE LARGE CARTRIDGE - KR			
	Volume nylon filter housing	75 Lt	<i>20 gal</i>
	Nylon filter area	5.5 mt²	<i>59 ft²</i>
	Filter disks	39 nr	
	Vol. large cartridge housing KR	75 Lt	<i>20 gal</i>
	Area large cartridge KR	2.6x3=7.8 mt²	<i>28x3=84 ft²</i>
	Cartridges quantity KR	nr 3	

TWO NYLON FILTER			
	Volume nylon filter housing	75x2=150 Lt	<i>20+20=40 gal</i>
	Nylon filter area	5,5x2=11 mt²	<i>59x2=118 ft²</i>
	Filter disks	39x2=78 nr	

ONE NYLON FILTER AND ONE DECOLORATING FILTER PR			
	Volume nylon filter housing	75 Lt	<i>20 gal</i>
	Nylon filter area	5.5 mt²	<i>59 ft²</i>
	Filter disks	39 nr	
	Decolorating housing volume PR	25 Lt	<i>6.6 gal</i>
	Decolorating cartridges	2 nr	
	Decolorating cabon quantity	4 kg	<i>8.8 Lbs</i>



DIMENSIONS AND WEIGHTS

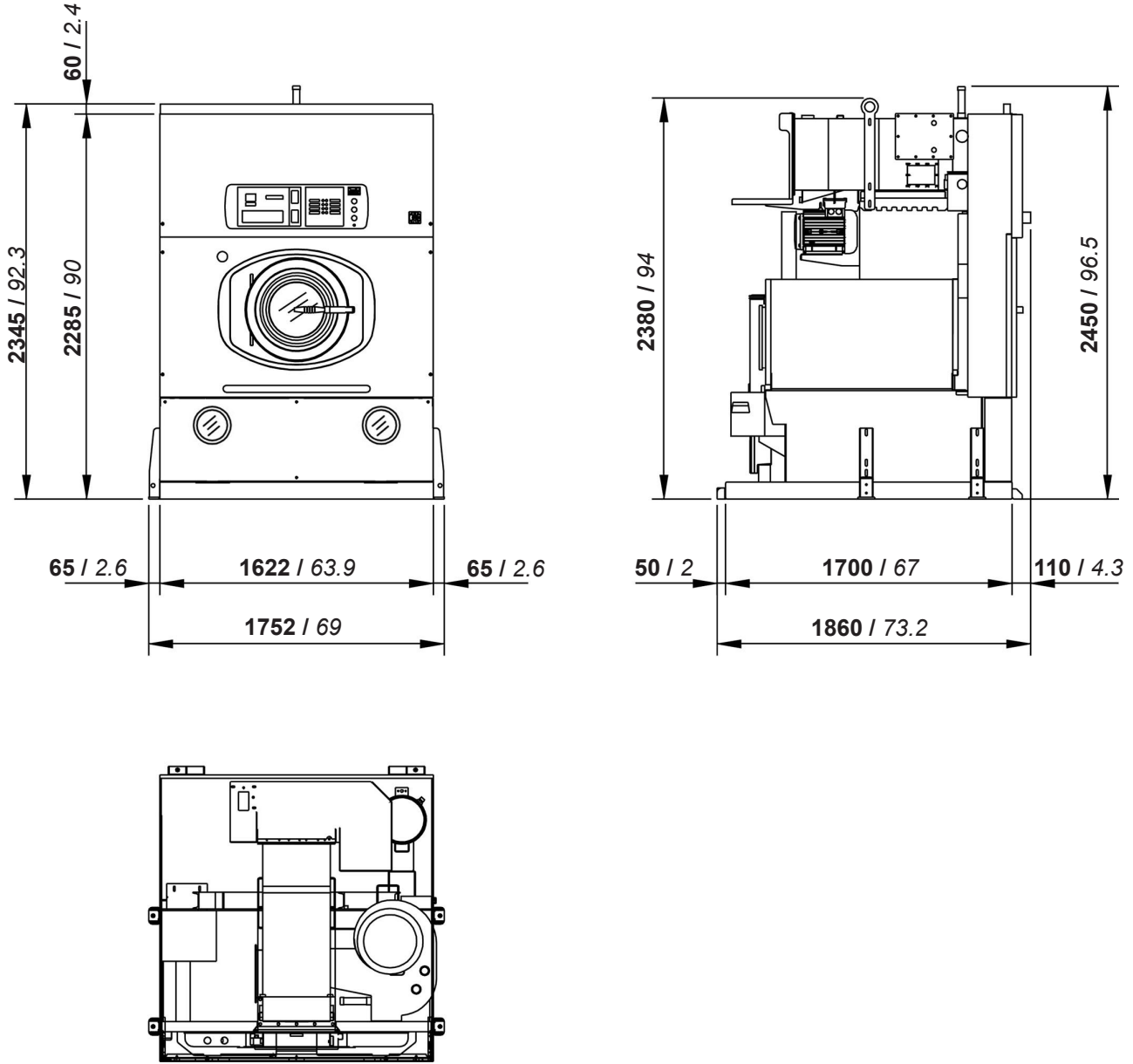

mm / inches

CHARGES		
Empty machine weight	1850 Kg	4079 Lbs
Machine weight with solvent	2200 Kg	4850 Lbs
Static charge on the floor with solvent	798 Kg/m²	163 Lbs/ft²
Dynamic charge on the floor (+10%)	1400 Kg/m²	287 Lbs/ft²



PACKAGED MACHINE DIMENSIONS AND WEIGHTS

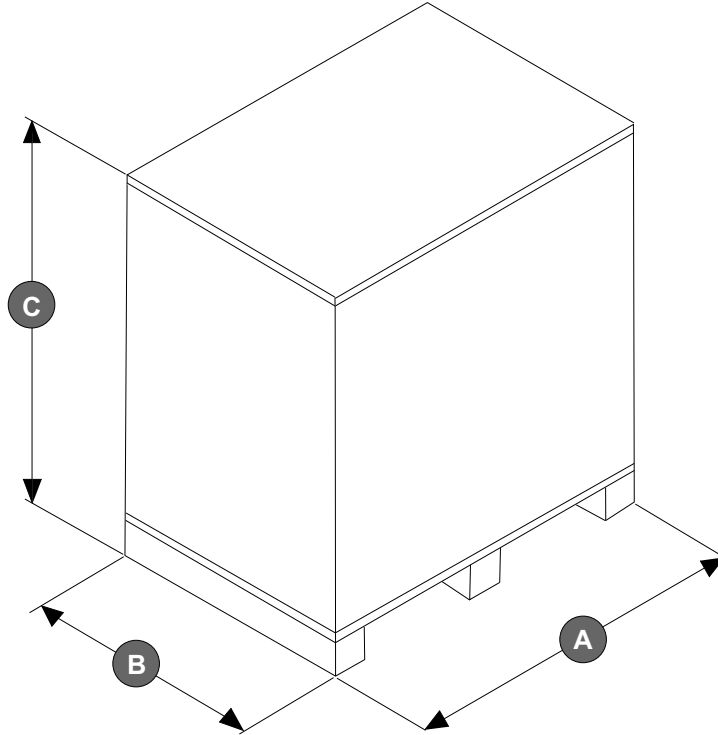

PACKAGED MACHINE DIMENSIONS							
Machine type		Carton		Wooden cage		Wooden case	
Standard	A	- mm	- inches	- mm	- inches	- mm	- inches
	B	- mm	- inches	- mm	- inches	- mm	- inches
	C	- mm	- inches	- mm	- inches	- mm	- inches

PACKAGED MACHINE WEIGHTS						
Machine type	Carton		Wooden cage		Wooden case	
Standard	- Kg	- Lbs	- Kg	- Lbs	- Kg	- Lbs



FIXING POINTS

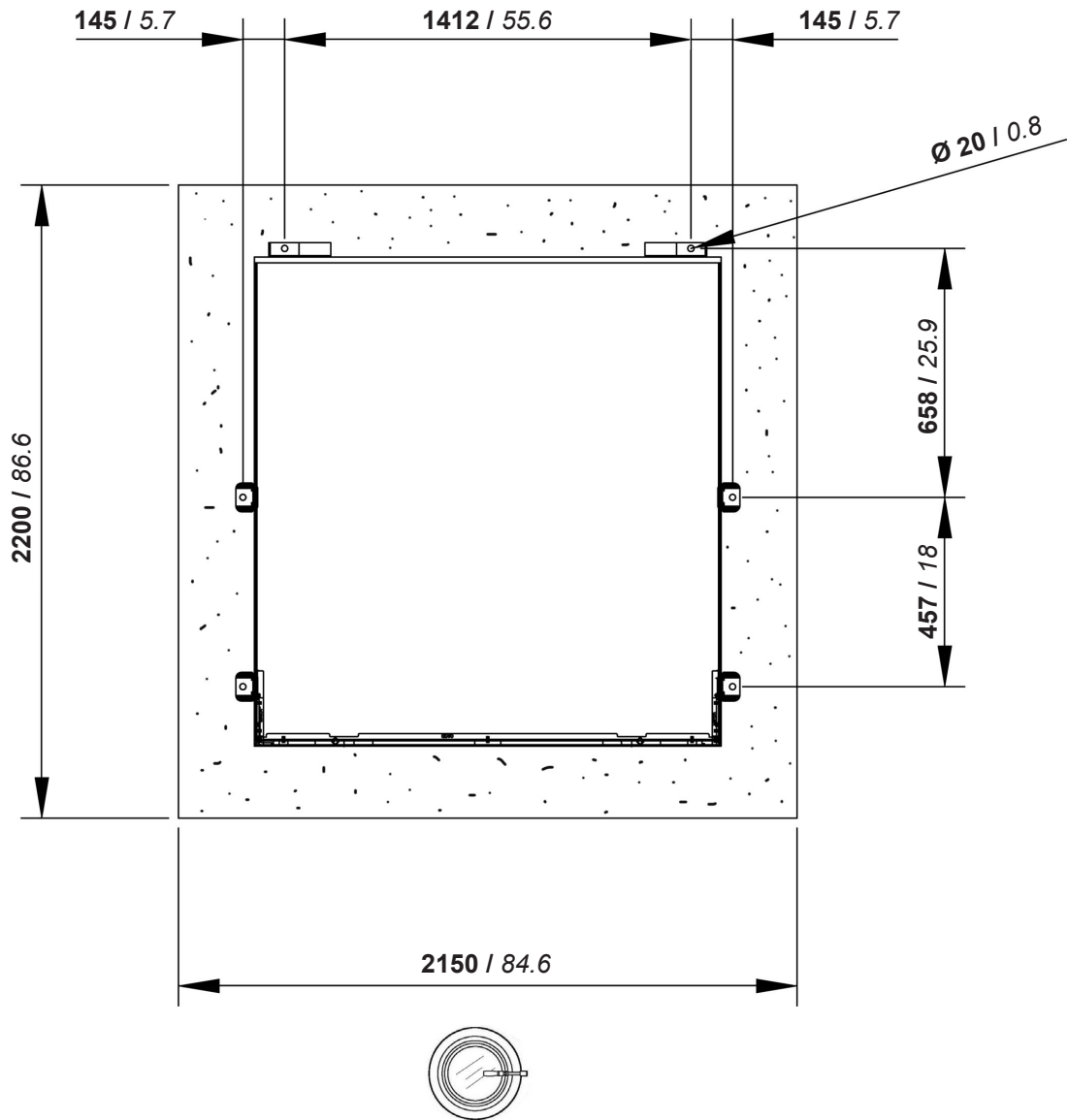
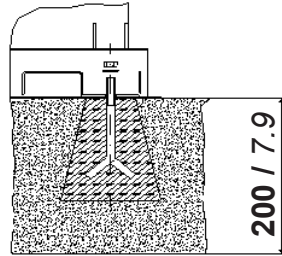

mm / inches



CONNECTIONS

A	Compressed air inlet	Ø 6mm	Ø 1/4"
B	Water inlet	Ø 3/4"	
C	Water outlet	Ø 3/4"	
D	Steam still inlet	-	
E	Condensate still outlet	-	
F	Steam heater inlet	Ø 1/2"	
G	Condensate heater outlet	Ø 1/2"	
H	Electric connection		
N	Nitrogen feeding connection (N ₂)		



NECESSARY QUANTITY OF SOLVENT TO FILL THE MACHINE				
Machine version - without Filters	380 Lt	293 Kg	<i>100 gal</i>	<i>646Lbs</i>
Machine version - 1 Nylon Filter	455 Lt	350 Kg	<i>120 gal</i>	<i>772 Lbs</i>
Machine version - 1 Nylon Filter + 1 KR	530 Lt	409 Kg	<i>140 gal</i>	<i>1168 Lbs</i>
Machine version - 2 Nylon Filters	530 Lt	409 Kg	<i>140 gal</i>	<i>1168 Lbs</i>
Machine version - 1 Nylon Filter + 1 Deco	480 Lt	370 Kg	<i>127 gal</i>	<i>1058 Lbs</i>

INFORMATION FOR THE ELECTRICAL CONNECTIONS (400V - 3~50Hz)		
ELECTRIC Version	-	-
STEAM Version	16 Kw	43 Amp
Dissipated heat	- Kcal	

INFORMATION FOR THE ELECTRICAL CONNECTIONS (220V - 3~60Hz)		
ELECTRIC Version	<i>- Kw</i>	<i>- Amp</i>
STEAM Version	19 Kw	60 Amp
Dissipated heat	- Kcal	

GENERAL INFORMATION		
Required water capacity	10 Lt/min	<i>2.6 gal/min</i>
Required water pressure	2 ÷ 3 bar	<i>29 ÷ 44 psi</i>
Required water temperature	18 ÷ 23 °C	<i>65 ÷ 73 °F</i>
Required air pressure	7 ÷ 8 bar	<i>100 ÷ 115 psi</i>
Required pressure	4 ÷ 5 bar	<i>55 ÷ 72 psi</i>
Required steam* availability (Steam Version)	20 Kg/h	<i>44 Lbs/h</i>

* Relative values of dry saturated steam.

All technical data are subject to change without notice.